

▶ SEPTIC TANK 1056 Gallon [4750 L] - 2 Compartment

MISCELLANEOUS INFORMATION

▶ PLAN VIEW

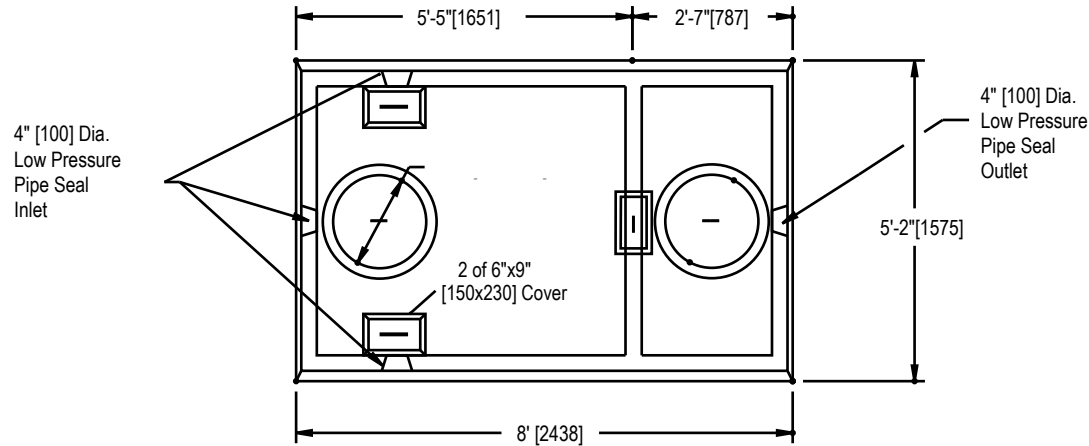

▶ SECTION THRU CENTERLINE

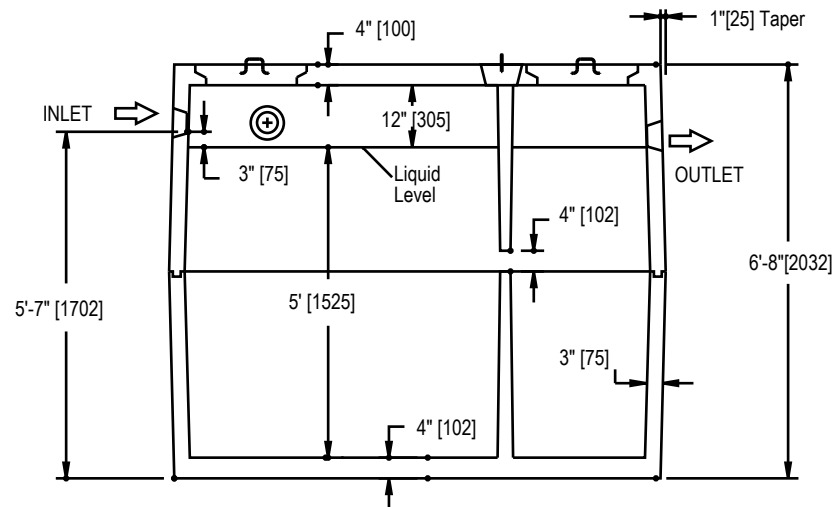

- ▶ **Description:**
- Tank 1056 Gal 2 Comp -top
 - Tank 1056 Gal 2 Comp -bot
 - Tank 1056 Gal 2 Compartment

- ▶ **Item #**
- Top: 10400
 - Bottom: 10500
 - Both: 10600

- ▶ **Weight lb/kg**
- Top: 4950/2245
 - Bottom: 4475/2030
 - Both: 9425/4275

- ▶ **Accessories:**
- Risers

- ▶ **Applications:**
- SepticTank
 - Privie Base
 - Valve Chamber
 - GreaseTrap

- ▶ **General Availability:**
- Windsor - Stock
 - Port Hastings - Stock

- ▶ **Mailing Address**
- RR# 3
Windsor NS B0N 2T0

- ▶ **Physical Address**
- 3901 Route 14
Windsor Forks, Nova Scotia

- ▶ **Phone:** 1-902-798-3188

- ▶ **Toll Free:** 1-800-565-7000

- ▶ **Fax:** 1-902-798-4322

- ▶ **Toll Free:** 1-888-767-7001

Specifications:

- Concrete Minimum Strength: 4640 psi [32 MPa] at 28 days
- Air Entraining: 5 - 8%
- Reinforcement: 10m Rebar & Structural Fibers
- Construction Joint: Sealed with butyl rope or equivalent
- Design for earth dead load only.
- Maximum bury - 2.0m
- Conforms to CAN/CSA-B66-M05

Notes:

- Wye and Pipe for Baffles Supplied by GSCP
- Low Pressure Pipe Seals Accomodate 2", 3", 4" Pipe



SEPTIC TANK
1056 Gallon [4750 L]
2 Compartment

Project:
Location:
Client:
Dwg. No.: 10600

Scale: NTS

Date: MAY/03
Dwn. By: DGM
Chk. By:
Sheet of

▶ SEPTIC TANK 1020 Gallon [4635 L] - One Piece

MISCELLANEOUS INFORMATION

▶ PLAN VIEW

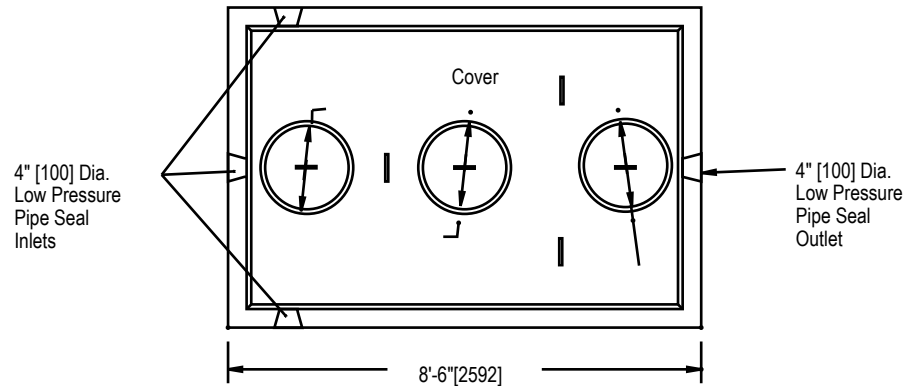

▶ SECTION THRU CENTERLINE

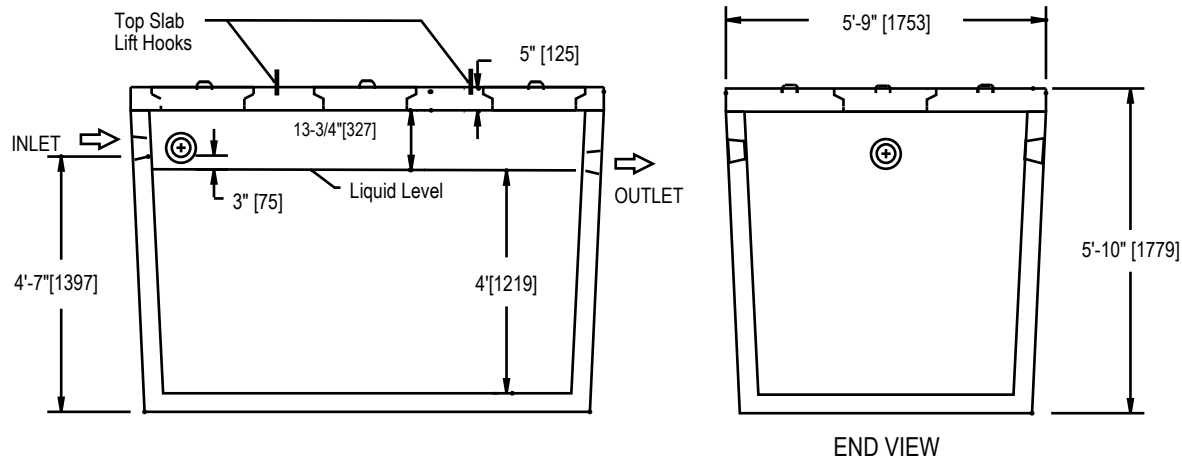

- ▶ **Description:**
- Tank 1020 Gal 1 Pce - bot
 - Tank 1020 Gal 1 Pce - cov
 - Tank 1020 Gal 1 Piece

- ▶ **Item #**
- Bottom: 11100
 - Cover: 11200
 - Both: 11300

- ▶ **Weight lb/kg**
- Bottom: 8300/3800
 - Top: 2300/1050
 - Both: 10600/4850

- ▶ **Accessories:**
- Risers

- ▶ **Applications:**
- Septic Tank
 - Pump Chamber
 - Privie Base
 - Pull Box
 - Valve Chamber
 - GreaseTrap

- ▶ **General Availability:**
- Windsor - Stock
 - Port Hastings - Special Order

- ▶ **Mailing Address**
- RR# 3
Windsor NS B0N 2T0

- ▶ **Physical Address**
- 3901 Route 14
Windsor Forks, Nova Scotia

- ▶ **Phone:** 1-902-798-3188

- ▶ **Toll Free:** 1-800-565-7000

- ▶ **Fax:** 1-902-798-4322

- ▶ **Toll Free:** 1-888-767-7001

Specifications:

- Concrete Minimum Strength: 4640 psi [32 MPa] at 28 days
- Air Entraining: 5 - 8%
- Reinforcement: 10m Rebar & Structural Fibers
- Construction Joint: Sealed with butyl rope or equivalent
- Design for earth dead load only.
- Maximum bury - 2.0m
- Conforms to CAN/CSA-B66-M05

Notes:

- Wye and Pipe for Baffles Supplied by GSCP
- Low Pressure Pipe Seals Accomodate 2", 3", 4" Pipe



SEPTIC TANK
1020 Gallon [4635 L]
One Piece

Project:
Location:
Client:
Dwg. No.: 11300

Scale: NTS

Date: MAY/03
Dwn. By: DGM
Chk. By:
Sheet of

▶ SEPTIC TANK 1250 Gallon [5681 L] - Low Profile

MISCELLANEOUS INFORMATION

▶ PLAN VIEW

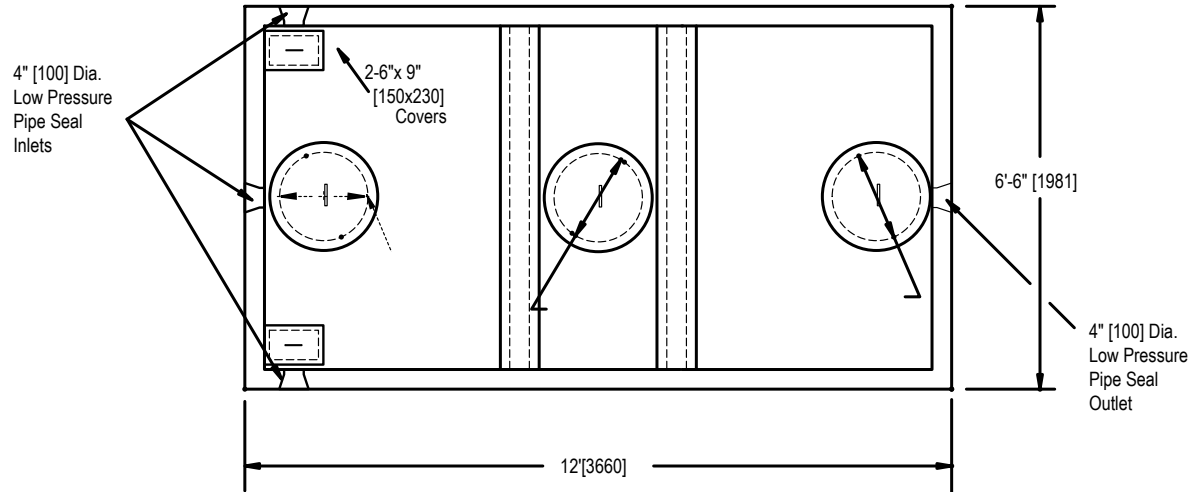

▶ SECTION THRU CENTERLINE

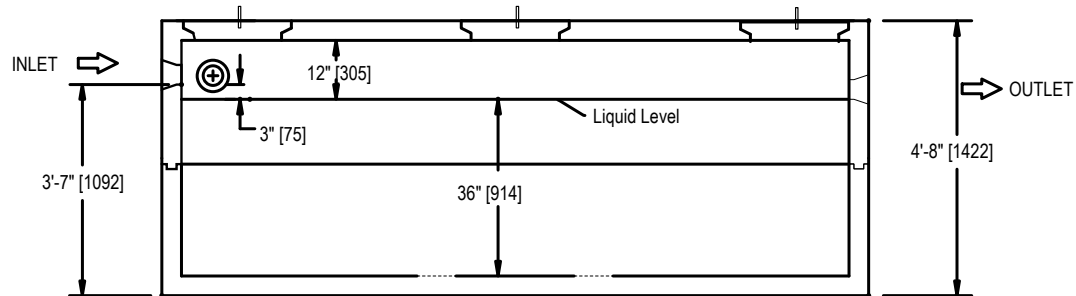

▶ Description:

- Tank 1250 Gal LP - top
- Tank 1250 Gal LP - bot
- Tank 1250 Gallon Low Profile

▶ Item

- Top: 12500
- Bottom: 12600
- Both: 12700

▶ Weight lb/kg

- Top: 7544/3422
- Bottom: 7155/3245
- Both: 14694/6665

▶ Accessories:

- Risers

▶ Applications:

- Septic Tank
- Pump Chamber
- Privie Base
- Pull Box
- Valve Chamber
- GreaseTrap

▶ General Availability:

- Windsor - Stock
- Port Hastings - Special Order

▶ Mailing Address

RR# 3
Windsor NS B0N 2T0

▶ Physical Address

3901 Route 14
Windsor Forks, Nova Scotia

▶ Phone: 1-902-798-3188

▶ Toll Free: 1-800-565-7000

▶ Fax: 1-902-798-4322

▶ Toll Free: 1-888-767-7001

Specifications:

- Concrete Minimum Strength: 4640 psi [32 MPa] at 28 days
- Air Entraining: 5 - 8%
- Reinforcement: 10m Rebar & Structural Fibers
- Construction Joint: Sealed with butyl rope or equivalent
- Design for earth dead load only.
- Maximum bury - 2.0m
- Conforms to CAN/CSA-B66-M05

Notes:

- Wye and Pipe for Baffles Supplied by GSCP
- Low Pressure Pipe Seals Accomodate 2", 3", 4" Pipe



SEPTIC TANK
1250 Gallon [5681 L]
Low Profile

Project:
Location:
Client:
Dwg. No.: 12700

Scale: NTS

Date: MAY/03
Dwn. By: DGM
Chk. By:
Sheet of

▶ SEPTIC TANK - 1600 Gallon [7300 L]

MISCELLANEOUS INFORMATION

▶ PLAN VIEW

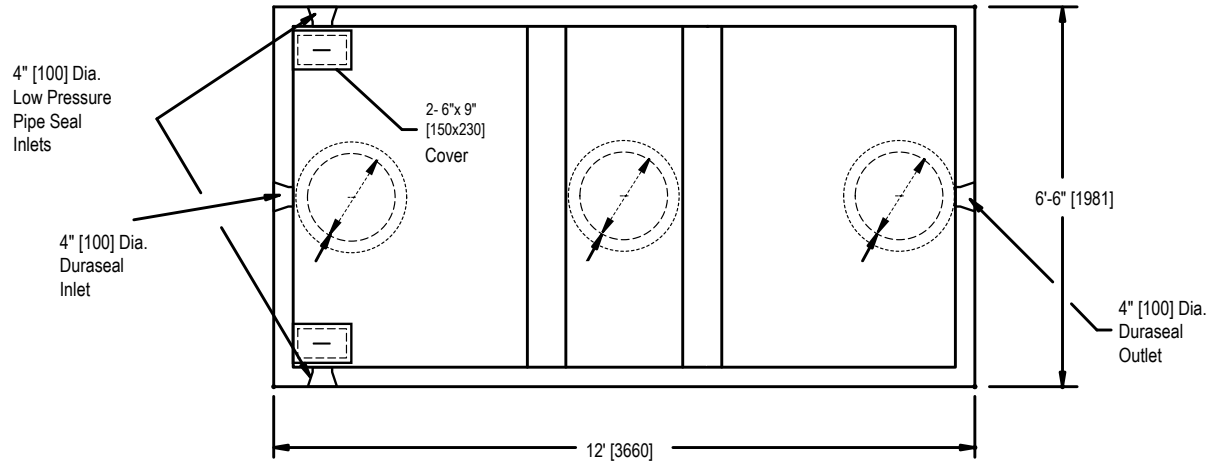

▶ SECTION THRU CENTERLINE

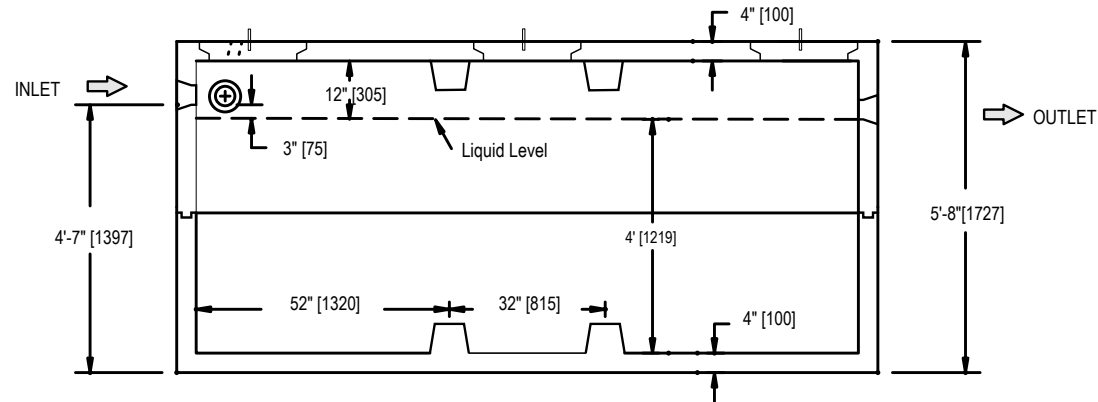

▶ Description:

- Top: Tank 1600 Gal - top
- Bottom: Tank 1600 Gal - bot
- Both: Tank 1600 Gallon

▶ Item

- Top: 16100
- Bottom: 16200
- Both: 16300

▶ Weight lb/kg

- Top: 9000/4082
- Bottom: 7900/3583
- Both: 16900/7665

▶ Accessories:

- Risers

▶ Applications:

- Septic Tank
- Pump Chamber
- Privie Base
- Pull Box
- Valve Chamber
- GreaseTrap

▶ General Availability:

- Windsor
- Port Hastings
- Stock
- Special Order

▶ Mailing Address

RR# 3
Windsor NS B0N 2T0

▶ Physical Address

3901 Route 14
Windsor Forks, Nova Scotia

▶ Phone: 1-902-798-3188

▶ Toll Free: 1-800-565-7000

▶ Fax: 1-902-798-4322

▶ Toll Free: 1-888-767-7001

Specifications:

- Concrete Minimum Strength: 4640 psi [32 MPa] at 28 days
- Air Entraining: 5 - 8%
- Reinforcement: 10m Rebar & Structural Fibers
- Construction Joint: Sealed with butyl rope or equivalent
- Design for earth dead load only.
- Maximum bury - 2.0m
- Conforms to CAN/CSA-B66-M05

Notes:

- Wye and Pipe for Baffles Supplied by GSCP
- Low Pressure Pipe Seals Accomodate 2", 3", 4" Pipe



SEPTIC TANK
1600 Gallon [7300 L]

Project:
Location:
Client:
Dwg. No.: 16300

Scale: NTS

Date: MAY/03
Dwn. By: DGM
Chk. By:
Sheet of

▶ SEPTIC TANK - 2000 Gallon [9100 L]

MISCELLANEOUS INFORMATION

▶ PLAN VIEW

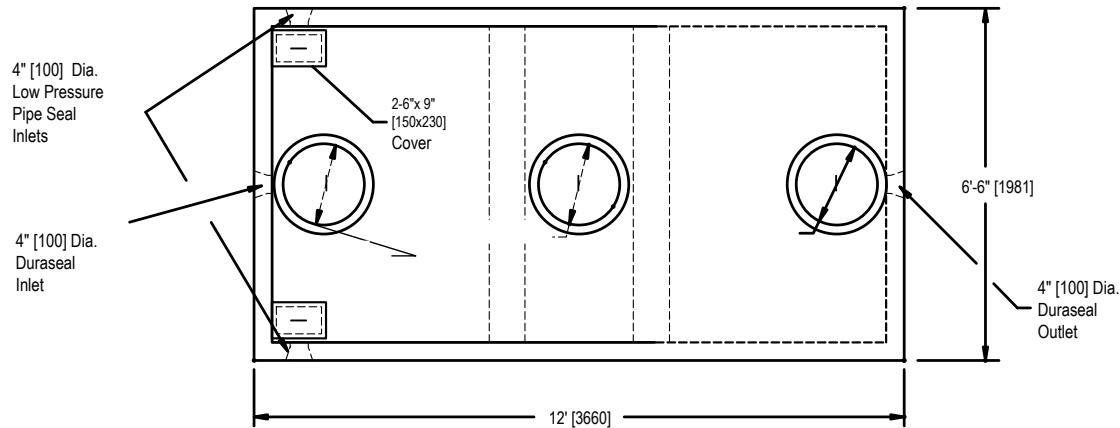

▶ SECTION THRU CENTERLINE

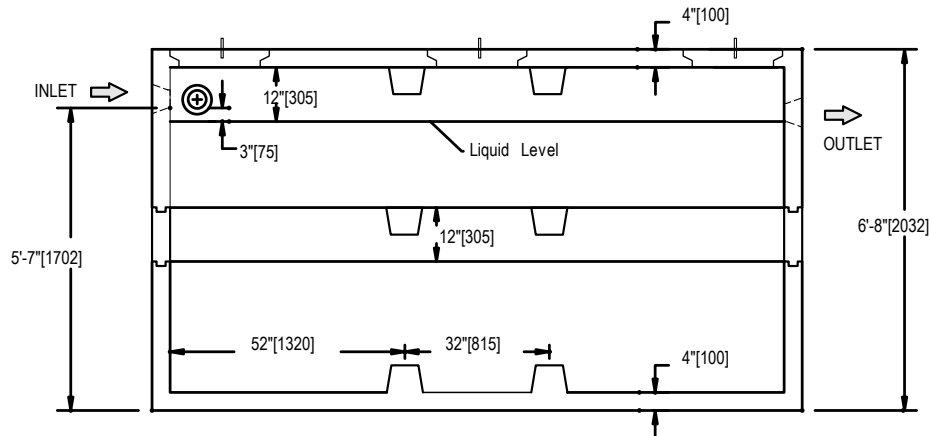

Specifications:

- Concrete Minimum Strength: 4640 psi [32 MPa] at 28 days
- Air Entraining: 5 - 8%
- Reinforcement: 10m Rebar & Structural Fibers
- Construction Joint: Sealed with butyl rope or equivalent
- Design for earth dead load only.
- Maximum bury - 2.0m
- Conforms to CAN/CSA-B66-M05

Notes:

- Wye and Pipe for Baffles Supplied by GSCP
- Low Pressure Pipe Seals Accomodate 2", 3", 4" Pipe

▶ Description:

- Top: Tank 1600 Gal - top
- Middle: Shim 12"
- Bottom: Tank 1600 Gal - bot
- All: Tank 2000 Gallon

▶ Item

- Top: 16100
- Middle: 20200
- Bottom: 16200
- All: 16400

▶ Weight lb/kg

- Top: 9000/4082
- Middle: 2300/1043
- Bottom: 7900/3583
- All: 19200/8708

▶ Accessories:

- Risers

▶ Applications:

- Septic Tank
- Pump Chamber
- Privie Base
- Pull Box
- Valve Chamber
- GreaseTrap

▶ General Availability:

- Windsor - Stock
- Port Hastings - Special Order

▶ Mailing Address

RR# 3
Windsor NS B0N 2T0

▶ Physical Address

3901 Route 14
Windsor Forks, Nova Scotia

▶ Phone: 1-902-798-3188

▶ Toll Free: 1-800-565-7000

▶ Fax: 1-902-798-4322

▶ Toll Free: 1-888-767-7001



SEPTIC TANK
2000 Gallon [9100 L]

Project:
Location:
Client:
Dwg. No.: 16400

Scale: NTS

Date: MAY/03
Dwn. By: DGM
Chk. By:
Sheet of

▶ SEPTIC TANK - 2500 Gallon [11400 L]

MISCELLANEOUS INFORMATION

▶ PLAN VIEW

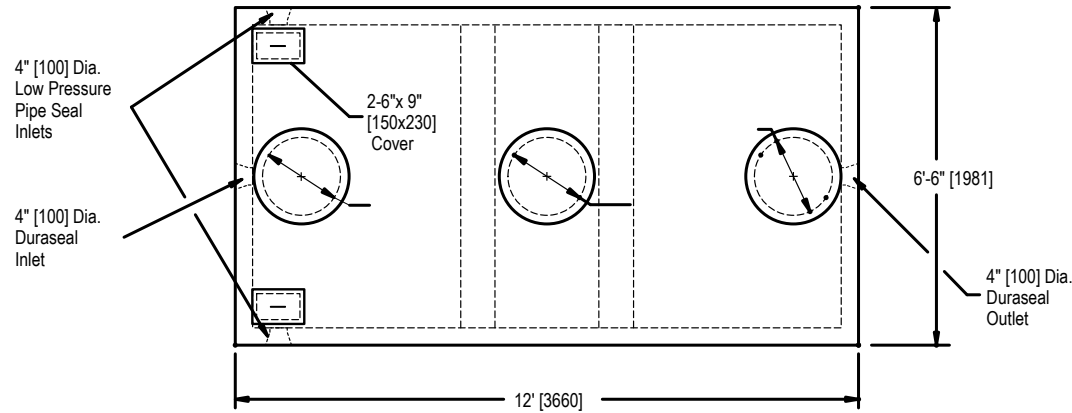

▶ SECTION THRU CENTERLINE

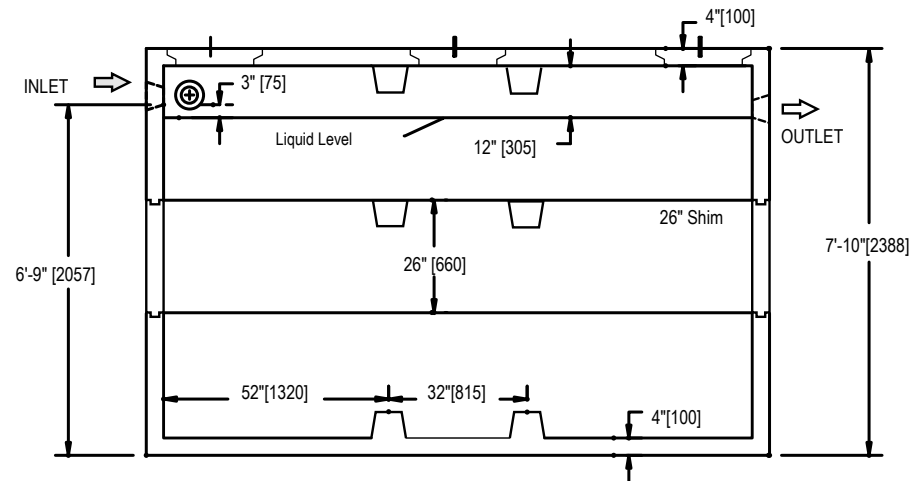

▶ Description:

- Top: Tank 1600 Gal - top
- Middle: Shim 26"
- Bottom: Tank 1600 Gal - bot
- All: Tank 2500 Gallon

▶ Item

- Top: 16100
- Middle: 25200
- Bottom: 16200
- All: 16500

▶ Weight lb/kg

- Top: 9000/4082
- Middle: 4350/1973
- Bottom: 7900/3583
- All: 21250/9639

▶ Accessories:

- Risers

▶ Applications:

- Septic Tank
- Pump Chamber
- Privie Base
- Pull Box
- Valve Chamber
- Grease Trap

▶ General Availability:

- Windsor
- Stock
- Port Hastings
- Special Order

▶ Mailing Address

RR# 3
Windsor NS B0N 2T0

▶ Physical Address

3901 Route 14
Windsor Forks, Nova Scotia

▶ Phone: 1-902-798-3188

▶ Toll Free: 1-800-565-7000

▶ Fax: 1-902-798-4322

▶ Toll Free: 1-888-767-7001

Specifications:

- Concrete Minimum Strength: 4640 psi [32 MPa] at 28 days
- Air Entraining: 5 - 8%
- Reinforcement: 10m Rebar & Structural Fibers
- Construction Joint: Sealed with butyl rope or equivalent
- Design for earth dead load only.
- Maximum bury - 2.0m
- Conforms to CAN/CSA-B66-M05

Notes:

- Wye and Pipe for Baffles Supplied by GSCP
- Low Pressure Pipe Seals Accomodate 2", 3", 4" Pipe



SEPTIC TANK
2500 Gallon [11400 L]

Project:
Location:
Client:
Dwg. No.: 16500

Scale: NTS

Date: MAY/03
Dwn. By: DGM
Chk. By:
Sheet of

▶ SEPTIC TANK - 3000 Gallon [13600 L]

MISCELLANEOUS INFORMATION

▶ PLAN VIEW

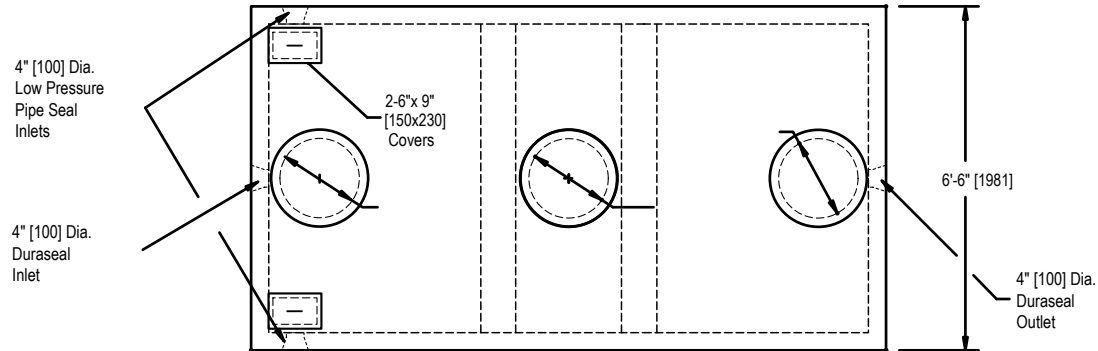

▶ SECTION THRU CENTERLINE

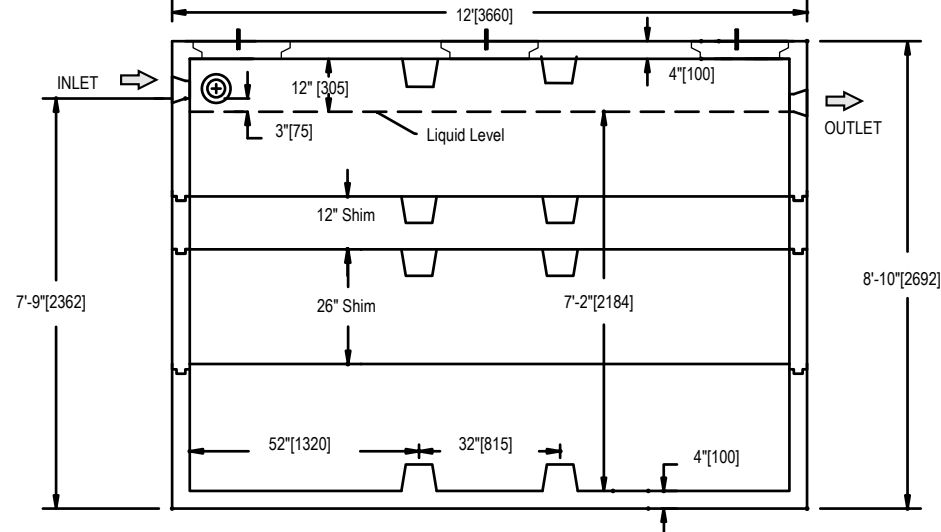

▶ Description:

- Top: Tank 1600 Gal - top
- Middle: Shim 12"
- Middle: Shim 26"
- Bottom: Tank 1600 Gal - bot
- All: Tank 3000 Gallon

▶ Item

- Top: 16100
- Middle: 20200
- Middle: 25200
- Bottom: 16200
- All: 16600

▶ Weight lb/kg

- Top: 9000/4082
- Middle: 2300/1043
- Middle: 4350/1973
- Bottom: 7900/3583
- All: 23550/10681

▶ Accessories:

- Risers

▶ Applications:

- Septic Tank
- Pump Chamber
- Privie Base
- Pull Box
- Valve Chamber
- GreaseTrap

▶ General Availability:

- Windsor
- Stock
- Port Hastings
- Special Order

Specifications:

- Concrete Minimum Strength: 4640 psi [32 MPa] at 28 days
- Air Entraining: 5 - 8%
- Reinforcement: 10m Rebar & Structural Fibers
- Construction Joint: Sealed with butyl rope or equivalent
- Design for earth dead load only.
- Maximum bury - 2.0m
- Conforms to CAN/CSA-B66-M05

Notes:

- Wye and Pipe for Baffles Supplied by GSCP
- Low Pressure Pipe Seals Accomodate 2", 3", 4" Pipe

▶ Mailing Address

RR# 3
Windsor NS B0N 2T0

▶ Physical Address

3901 Route 14
Windsor Forks, Nova Scotia

▶ Phone: 1-902-798-3188

▶ Toll Free: 1-800-565-7000

▶ Fax: 1-902-798-4322

▶ Toll Free: 1-888-767-7001



SEPTIC TANK
3000 Gallon [13600 L]

Project:
Location:
Client:
Dwg. No.: 16600

Scale: NTS

Date: MAY/03
Dwn. By: DGM
Chk. By:
Sheet of

▶ SEPTIC TANK - 3500 Gallon [15900 L]

MISCELLANEOUS INFORMATION

▶ PLAN VIEW

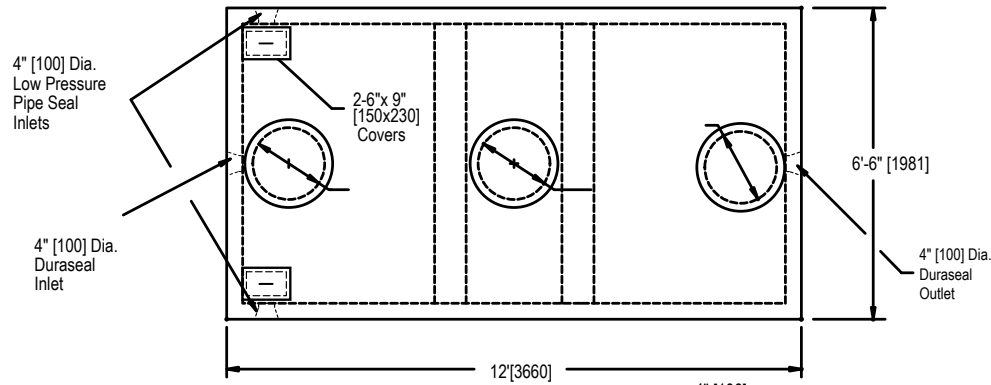

▶ SECTION THRU CENTERLINE

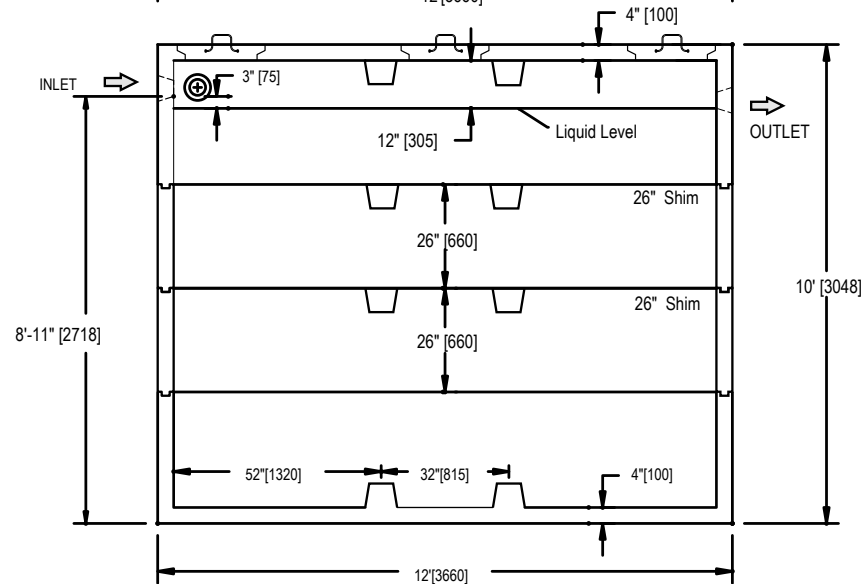

▶ Description:

- Top: Tank 1600 Gal - top
- Middle: Shim 26"
- Middle: Shim 26"
- Bottom: Tank 1600 Gal - bot
- All: Tank 3500 Gallon

▶ Item

- Top: 16100
- Middle: 25200
- Middle: 25200
- Bottom: 16200
- All: 16650

▶ Weight lb/kg

- Top: 9000/4082
- Middle: 4350/1973
- Middle: 4350/1973
- Bottom: 7900/3583
- All: 25600/11611

▶ Accessories:

- Risers

▶ Applications:

- Septic Tank
- Pump Chamber
- Privie Base
- Pull Box
- Valve Chamber
- GreaseTrap

▶ General Availability:

- Windsor - Stock
- Port Hastings - Special Order

Specifications:

- Concrete Minimum Strength: 4640 psi [32 MPa] at 28 days
- Air Entraining: 5 - 8%
- Reinforcement: 10m Rebar & Structural Fibers
- Construction Joint: Sealed with butyl rope or equivalent
- Design for earth dead load only.
- Maximum bury - 2.0m
- Conforms to CAN/CSA-B66-M05

Notes:

- Wye and Pipe for Baffles Supplied by GSCP
- Low Pressure Pipe Seals Accomodate 2", 3", 4" Pipe

▶ Mailing Address

RR# 3
Windsor NS B0N 2T0

▶ Physical Address

3901 Route 14
Windsor Forks, Nova Scotia

▶ Phone: 1-902-798-3188

▶ Toll Free: 1-800-565-7000

▶ Fax: 1-902-798-4322

▶ Toll Free: 1-888-767-7001



SEPTIC TANK
3500 Gallon [15900 L]

Project:
Location:
Client:
Dwg. No.: 16650

Scale: NTS

Date: MAY/03
Dwn. By: DGM
Chk. By:
Sheet of