

ARES[®] RETAINING WALL SYSTEMS

INSTALLATION GUIDE AND CONSTRUCTION MANUAL

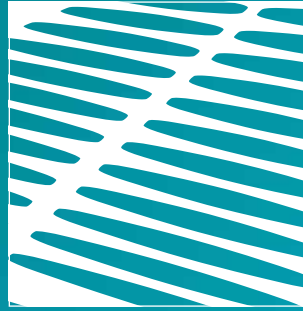

› When long-term performance and speed of construction are important, ARES® Retaining Wall Systems offer unmatched advantages.



Tensar® Geogrids

The ARES Retaining Wall Systems owe their long-term performance and durability to high strength **Tensar® Uniaxial (UX) Geogrids**. Due to their stiff interlocking capabilities, these geogrids stand the test of time, outperforming other commercially available geosynthetics. For more information, visit www.tensarcorp.com.

ARES® Retaining Wall Systems

DOTs, Contractors and Engineers have long appreciated the many advantages of panel walls. Their wide range of appearances and finishes, combined with the simplicity and speed of construction, make them attractive when compared to other types of wall systems. Unfortunately, limitations imposed by the behavior of reinforcing materials and a very narrow and expensive range of acceptable backfill materials have restricted their use until the introduction of Geogrids manufactured by Tensar International Corporation (Tensar). By mechanically connecting Tensar Geogrids with the advantages of panels, the fully integrated ARES® Retaining Wall Systems now offer a high-performance, cost-effective and aesthetically pleasing solution.

NO METAL - NO CORROSION

With soil reinforcement that is 100% polymeric, ARES Retaining Wall Systems are proven concrete panel wall solutions that eliminate corrosion concerns of soil reinforcement. ARES Systems offer cost advantages over conventional panel walls while eliminating the risks associated with the long term exposure to chlorides, sulfates, low-resistivity soils or stray electric current potential. This makes the system the logical choice for “hot” backfill soils, transformer platform areas and electrified rail systems.

As testimony to the durability of the ARES Systems, one of the first Tensar-reinforced panel walls was built as a seawall on the Gaspé Peninsula in Canada. After 30 years of North Atlantic storms and constant exposure to salt water, there are no signs of deterioration of the soil reinforcement. In fact, some of the first ARES installations were instrumented and carefully observed to verify the effectiveness and long-term performance of the systems. As part of an FHWA study at the Tanque Verde project in Arizona, the Tensar Geogrid behind sections of one such ARES wall was excavated to validate its durability. Thirty years after the original installation, the walls continue to perform as designed with no maintenance issues.

PURPOSE OF THIS DOCUMENT

This document is intended to provide the Owner, Engineer, Contractor and the Inspector with the guidelines and criteria required to facilitate construction and quality control of the ARES Precast Panel Retaining Wall System.

ARES® Systems' Components

COMPONENT	FUNCTION
Tensar Geogrids	High-density polyethylene (HDPE) structural geogrids internally reinforce the fill materials. Inert to chemical degradation, they can be used with different backfill materials, even crushed concrete.
Precast Panel Facing	Available in standard 5 ft x 5 ft (1.5 m x 1.5 m), 5 ft x 9 ft (1.5 m x 2.75 m), 5 ft x 10 ft (1.5 m x 3.0 m) or can be customized for full height construction.
Bodkin Connector	HDPE Connector for high connection efficiency without the concern for corrosion.
Full Engineering and Construction Services	Detailing, design, site assistance and stamped drawings for each ARES project upon request.

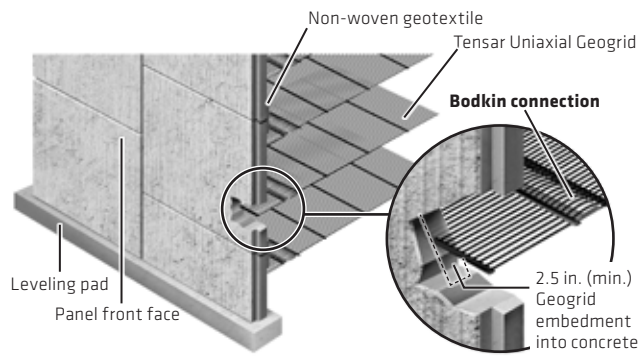

FIGURE 1:
*ARES® Retaining
 Wall System -
 incremental
 5 ft x 5 ft panel*

Wall Component Definitions

The following are standard terms that will be used for the ARES® Retaining Wall Systems. Refer to Figures 1 and 2 for a typical cross-section and the associated terms.

- ▶ **Bearing Pads** – Wall panel spacers are typically ribbed elastomeric or polymeric pads. They are inserted at the horizontal joint between panels to help provide the proper spacing. Proper spacing keeps the panels from having point contact and spalling the concrete.
- ▶ **Bodkin Connection** – This is where the connection is made between the wall facing panel and the soil reinforcement.
- ▶ **Concrete Leveling Pad** – The leveling pad is unreinforced cast-in-place concrete for precast panel facing to sit on a level foundation.
- ▶ **Coping** – The coping is used to tie in the top of the wall panels and to provide a pleasing finish to the wall top. It is cast-in-place or precast.
- ▶ **Filter Fabric** – Typically a non-woven geotextile fabric is used to cover the joint between panels. It is placed on the backside of the panel joints. This keeps the soil from piping through the joints and allows excess water to flow out.

- ▶ **Random Backfill (retained)** – Random backfill is the backfill that is retained.
- ▶ **Select Backfill** – Select granular backfill within the reinforced mass that meets the gradation, unit weight, internal friction angle and any other requirements.
- ▶ **Temporary Wooden Wedges** – Are used to help hold the panels at the correct batter during the backfilling operation.
- ▶ **Tensar Structural Geogrid** – Soil reinforcement that holds the wall facing panels in position and provides reinforcement for the soil.
- ▶ **Wall Facing Panel** – Wall facing panels are used to hold the soil in position at the face of the wall. The panels are made of precast concrete.

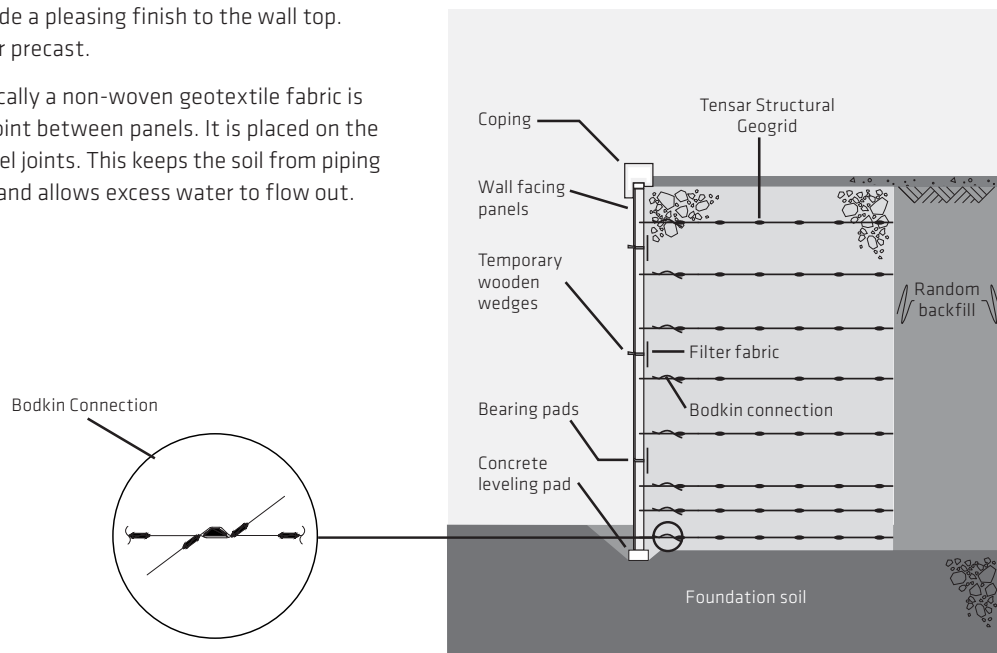

FIGURE 2: Typical Cross Section



MSE Wall Construction Best Practices

- ▶ Confirm receipt of the Tensor approved construction drawings.
- ▶ Confirm backfill material has been tested and approved before it is brought to the job site.
- ▶ Review the approved construction drawings.
- ▶ Ensure the Contractor's field supervisor has a copy of the approved construction drawings as well as Tensor Installation Guide and is familiar with them.
- ▶ Confirm the foundation soils are in accordance with project specifications.
- ▶ Confirm the leveling pad elevations, alignment and step locations prior to pouring the concrete.
- ▶ Notify the Tensor project manager of the expected start date for panel installation.
- ▶ Ensure panels, geogrid and accessories are properly stored to prevent damage.
- ▶ Inspect geogrid, accessories and panels for damage. Notify Tensor of any materials that are not in compliance with the plans and specifications.
- ▶ Install panels in accordance with the plans and specifications.
- ▶ Use corner panels at all corners. If corner panels are not indicated on the Tensor approved construction drawings, Tensor should be notified.
- ▶ Ensure wedges are installed on each course of panels. Use hardwood wedges.
- ▶ Check the batter of the panels daily (at a minimum) and adjust the initial batter accordingly. The vertical alignment of the panels below the panels being installed may be affected by the compaction of the soil behind those panels.
- ▶ When installing the filter fabric to the panel apply the adhesive to the panel and then apply the fabric.
- ▶ Place and compact fill in accordance with the plans and specifications. If fill lift thickness is not included in the plans and specifications, do not exceed fill lifts thicker than 10 in. (250 mm) loose. Thick lifts may cause the panels to move out of alignment.
- ▶ Ensure the geogrid reinforcement can be installed around all obstructions without skewing the geogrid more than 15 degrees from normal. Notify Tensor of any obstructions not shown on the Tensor approved construction drawings.



- ▶ ARES® modular panels provide significant face area while the Tensar® Geogrid reinforcement is lightweight and easy to field connect.

Responsibilities for Construction Compliance

- ▶ The Contractor is responsible to provide construction in accordance with the contract documents and to coordinate the wall construction with related work.
- ▶ The Contractor is responsible for using the most recent set of approved construction drawings to perform the work and for verifying line, grade and offset needed to establish wall location according to the contract documents.
- ▶ The Contractor is responsible for monitoring material supply and ensuring that adequate lead time is provided with each request for delivery and that ordered quantities are available to prevent construction delays.
- ▶ The Contractor is responsible for unloading and inspecting materials upon delivery to the job site, and to provide proper storage and protection of materials.
- ▶ The Engineer is responsible for enforcing the requirements of the contract documents and the approved construction drawings.
- ▶ The Tensar technical advisor will be available at the start of the project to advise the Contractor's project team of the recommended construction procedures within the scope of this manual. The Tensar technical advisor is not a member of the inspection or quality control staff on the project.

Work provided by the Contractor includes:

- ▶ All wall site preparation and survey layout
- ▶ Forming and pouring the leveling pad
- ▶ Wall construction in its entirety according to approved construction drawings
- ▶ Installation of the top-of-wall treatment where required

If requested, services provided by Tensar include:

- ▶ Wall construction drawings
- ▶ On-site technical assistance at the start of construction





Materials

TYPICAL MATERIALS SUPPLIED BY TENSAR

- ▶ Precast concrete facing panels
- ▶ HDPE Tensar® Uniaxial (UX) Geogrid
- ▶ Filter fabric
- ▶ Bearing pads
- ▶ Bodkin bars

Materials supplied by Tensar are typically delivered in full truck load quantities. Off-loading is scheduled by the Contractor.

Any damage to the materials or discrepancies in quantities must be noted by the Contractor on the delivery ticket at the time of delivery and reported promptly to Tensar. The materials must be properly stored in such a manner and location to avoid damage or theft.



HDPE Tensar Uniaxial (UX) Geogrids can be color-coded to differentiate roll types.



ARES® panels typically arrive at the job site on flatbed trucks.



Palletized component materials upon arrival at site.

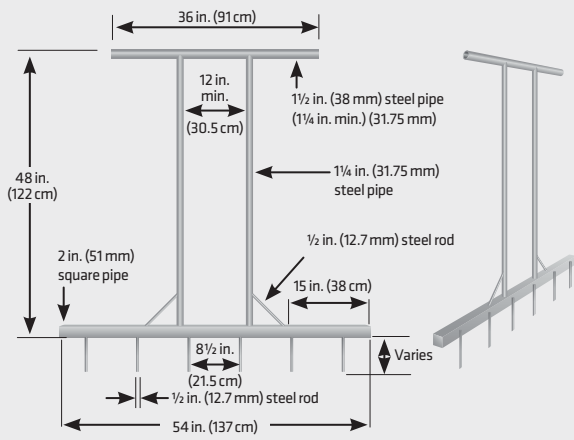

FIGURE 3: Sample configuration of steel rake for tensioning geogrid.

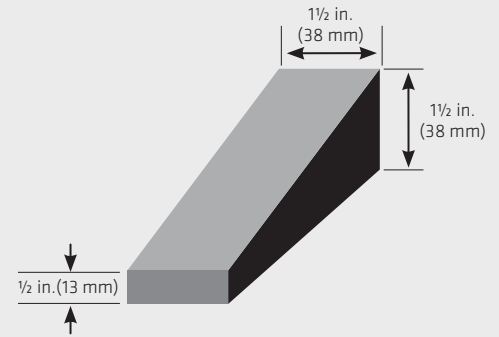

FIGURE 4: Temporary Wooden Wedge, two per horizontal joint required on 5 x 5 and four per horizontal joint required on 5 x 9 and 5 x 10.

Materials (continued)

MATERIALS AND TOOLS PROVIDED BY THE CONTRACTOR:

- ▶ Nylon slings for unloading panels
- ▶ Equal length cables with shackles to connect the lifting devices
- ▶ Devices for lifting panels by the embedded lifting inserts
- ▶ Rake for tensioning geogrid (Figure 3)
- ▶ Lumbers for bracing, staking, and fabrication of clamps, as well as threaded rod, washers and nuts
- ▶ Hardwood wedges (Figure 4)
- ▶ Standard and Header Clamps (Figures 5 and 6)
- ▶ 3/4 in. (19 mm) plywood spacer to set panel vertical joints gap
- ▶ Spray paint for marking geogrid and panels
- ▶ Standard grade construction adhesive such as Liquid Nail or 3M 77 to attach the filter fabric to the panels at the joints
- ▶ Crowbars, 4 ft (1.2 m) long
- ▶ Wrenches for clamp bolts
- ▶ Sledge and Claw hammers
- ▶ Broom for sweeping the leveling pad
- ▶ Sharp blade or scissors to cut the filter fabric
- ▶ 4 ft (1.2 m) level
- ▶ Chalk line
- ▶ Plumb bob
- ▶ Concrete, steel, and forming materials for leveling pad and top of the wall treatment as required
- ▶ Backfill materials

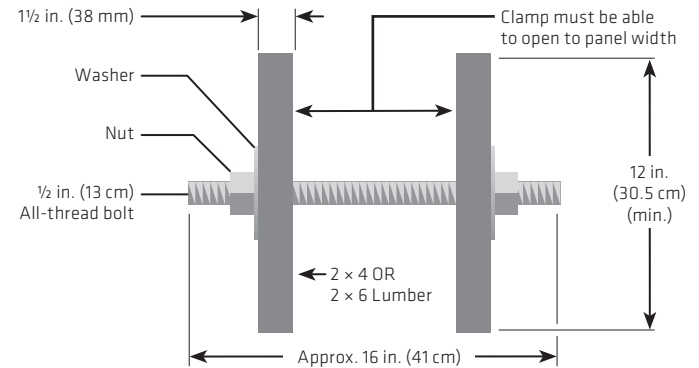

FIGURE 5: Standard Clamp: One per vertical joint

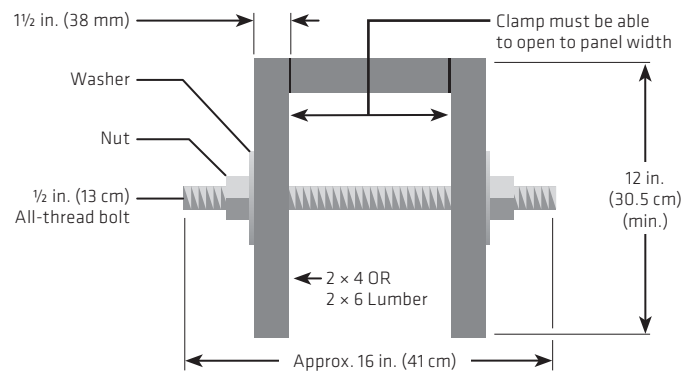

FIGURE 6: Bracing Header Clamp: For initial course only



Materials (continued)

EQUIPMENT PROVIDED BY CONTRACTOR

- ▶ Panel handling and setting equipment – excavator, loader or similar equipment capable of properly lifting and placing the precast concrete facing panels.

NOTE: Typical weight of largest standard panel type is approximately 3,000 lbs (1,360 kg) for projects using nominal 5 ft (1.5 m) wide, 5.5 in. (140 mm) thick panels, approximately 5,500 lbs (2,495 kg) for projects using nominal 9 ft (2.75 m) wide, 5.5 in. (140 mm) thick panels, and approximately 6,000 lbs (2,720 kg) for 10 ft (3 m) wide, 5.5 in. (140 mm) thick panels.

- ▶ Equipment to transport the select fill to the wall site.
- ▶ Equipment, such as a rubber-tired loader and small track dozer, preferably with angle blade, for placing and spreading the select fill.
- ▶ Large, smooth-drum roller for mass compaction
- ▶ Small, hand-operated, vibratory plate tamper or roller for compaction within 3 ft (0.9 m) of the back face of wall panel.

NOTE: Use of Jumping Jack is not recommended.



IMAGE A:
 ARES® panels should be stacked on a level, stable surface provided by the Contractor. Dunnage shall be carefully selected to allow panel separation and placed to avoid panel cracking.



Handling Materials Supplied by Tensar

All materials supplied by Tensar shall be properly stored in a secure location to prevent damage or theft.

PRECAST CONCRETE FACING PANELS

- ▶ It is the responsibility of the Contractor to schedule delivery of the panels in accordance with the installation schedule. Proper coordination will help avoid delays by having the precasting performed in harmony with the wall construction schedule.
- ▶ ARES® panels are usually delivered on flatbed trailers. The Contractor must provide a level, stable area to unload and stage panels. The acceptability of this access is at the discretion of the driver or his employer. The Contractor is allowed one hour to unload each truck, unless specifically agreed otherwise in writing with Tensar.
- ▶ The Contractor must take care to protect the panels from staining due to rain splash or damage due to improper placement of the dunnage. The number of panels in a stack shall not exceed five 5 x 5 panels, four 5 x 9 panels or four 5 x 10 panels as shown in Image A.

- ▶ The dunnage shall be properly spaced to avoid uneven loading in the panel stacks. (See Figure 7.) **All dunnages are the property of Tensar or its precaster and should be stacked by the Contractor for loading on a subsequent panel delivery truck.**
- ▶ Delivery tickets are included with each shipment and indicate the panel types furnished in that load. It is the responsibility of the Contractor to confirm the accuracy of the tickets and to note any damage that is visible prior to accepting delivery. Tensar or its precaster must be notified immediately if any panels have been damaged.

BEARING PADS FOR HORIZONTAL JOINTS BETWEEN PANELS

- ▶ Bearing pads will be delivered in cardboard cartons.
- ▶ The quantity of these cartons shall be noted on the delivery ticket and confirmed by the Contractor.

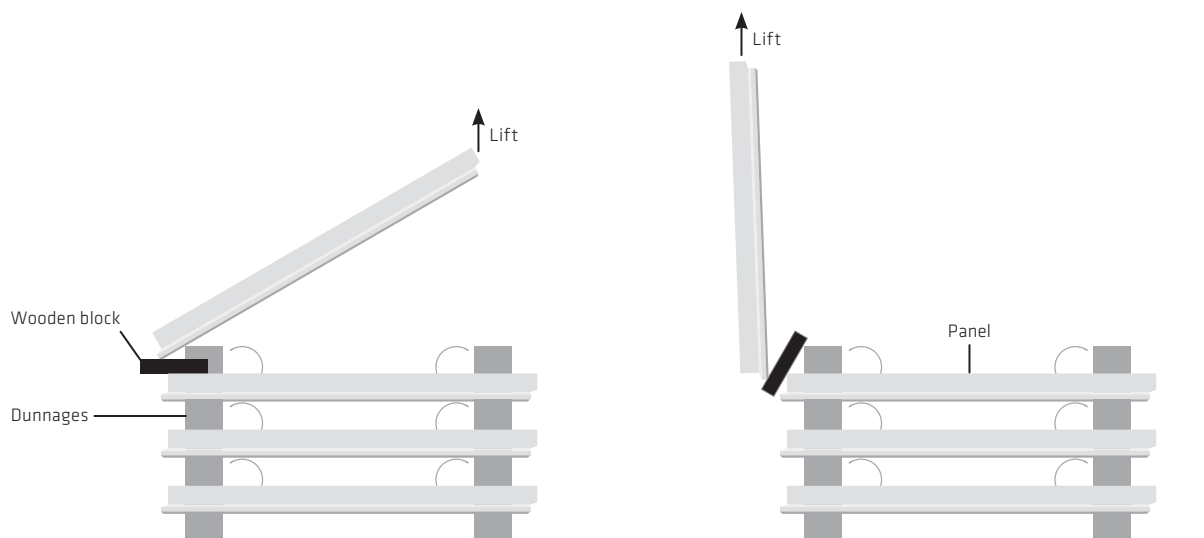

FIGURE 7: Suggested stacking and lifting procedures for ARES segmental panels.



► Color-code the geogrid tabs on each panel to correspond with the geogrid rolls.

GEOGRID REINFORCEMENT

- Geogrid reinforcement shall be delivered in rolls and shall be labeled by type. These labels must be protected until the geogrid has been color-coded at the job site. The Contractor should retain any certifications included with the packing slip for the Engineer.
- The Contractor should immediately color code each of the geogrid types using spray paint on the edges and ends of the rolls (Images B and C). The Contractor may choose to highlight geogrid types on the approved construction drawings using corresponding colors.
- The Contractor is responsible for cutting the geogrid to length in the field. Precut geogrid should then be tagged for length and type. The first transverse bar (at the connection) on each section of geogrid should be trimmed neatly to expedite making the connection of the geogrid to the wall facing. Do not cut into the transverse bar of the geogrid (Figure 8 and Image D).



IMAGE B:
Uniaxial geogrid rolls should be color-coded prior to removing roll labels.



IMAGE C: Color coding of geogrid panels allows for quick, accurate identification even after labels are removed.

FILTER FABRIC

- The filter fabric will be delivered in rolls and must be covered to protect it from direct sunlight.

FIGURE 8

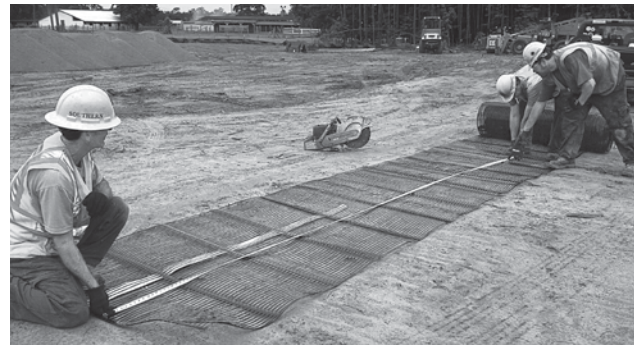
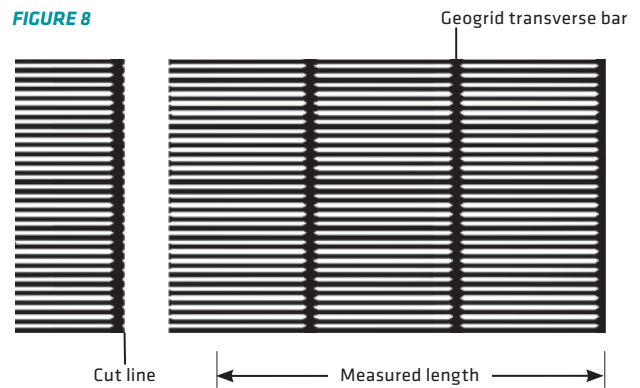

IMAGE D: Safe cutting of geogrid may be accomplished with a variety of cutting tools. Care should be taken to avoid cutting the transverse bar.

► As with any wall system, the foundation is crucial to the wall's performance.



Construction Procedures for ARES® Retaining Wall Systems

EXCAVATION, FOUNDATION AND DRAINAGE

- Excavation will be performed to the lines and grade required for the installation of the entire wall system.
- The Contractor will be responsible for supporting the wall excavation. All work to support the excavation or to fill the void behind the wall will be the responsibility of the Contractor.
- Evaluation and approval of foundation suitability is the responsibility of the Engineer. Any foundation soils found to be unsuitable by the Engineer shall be removed and replaced with material suitable to the Engineer. The material shall be compacted to the density necessary to obtain the bearing pressure required by the Contract Documents, including the Project Plans and Specifications.
- Foundation shall be prepared according to contract documents and project specifications. The foundation is crucial to the performance of any panel wall system.
- The wall drainage system shall be installed as required in the Contract Documents.

CAST-IN-PLACE LEVELING PAD

- Once the foundation is prepared and approved by the Engineer, an unreinforced concrete pad is constructed. The purpose of this pad is to serve as a guide for the wall panel construction. This leveling pad is not intended for 'significant' structural foundation support in the final configuration of the wall. There is significant construction panel loading on the leveling pad, and it must be properly constructed and on a firm foundation in order to minimize potential wall movement during the construction of the wall.
- The leveling pad is important to the overall construction of the wall and the horizontal and vertical alignment of the wall. It must be in the correct horizontal position, level and at the correct grade.
- Unless otherwise shown in the contract documents or approved in writing by the Engineer, the leveling pad shall consist of 6 in. (150 mm) thick by 12 in. (300 mm) wide unreinforced concrete which shall be formed and poured in place. The concrete strength shall be in accordance with the contract documents or a minimum of 2,500 psi (17MPa), whichever is greater. The leveling pad must cure a minimum of 12 hours prior to the placement of the panels.

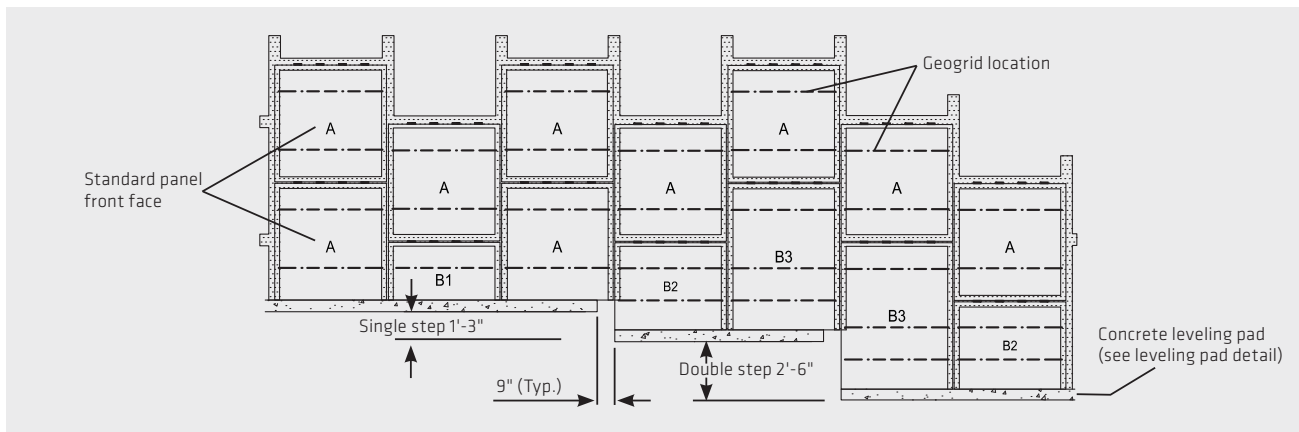

FIGURE 9: Example of leveling pad and typical panels configuration.



IMAGE E: Panel placement commonly begins at corner locations. Placement and bracing of concrete panels.

- ▶ The leveling pad shall have formed sides and a smooth, level surface set to the grades as shown on the approved construction drawings and shall be finished such that the elevation variance is less than $+1/8$ in. (3 mm) or $-1/4$ in. (6 mm). A leveling pad that is not placed accurately will create problems with wall alignment and joint spacing during the construction process.
- ▶ Where steps in the leveling pad are shown on the approved construction drawings, the actual location of each step should be located and the bulkhead for the upper leveling pad step set back 9 in. (225 mm), nominal. (See Figure 9 and Image G.)
- ▶ After the concrete has cured and the forms are removed, lay out the front face of the wall and establish the location on the leveling pad by striking a chalk line at the front face of the bottom course of panels. (See Image F.) For panels with an architectural finish, the location and chalk line should be based on the face of the structural, non-architectural portion of the panel, i.e. immediately behind the architectural relief.
- ▶ Do not allow any overhanging of the panels off the leveling pad. If this happens, stop the construction and investigate the problem.

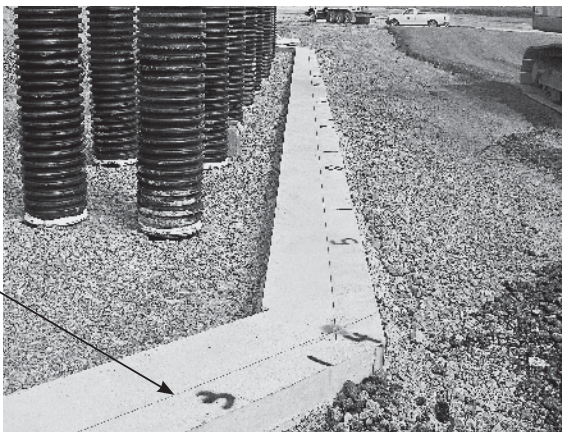

IMAGE F: Recommended location of chalk line on leveling pad.

PANEL PLACEMENT – BOTTOM COURSE

- ▶ At this point, the foundation has been constructed, drainage has been added, the materials have been checked and the leveling pad has been constructed. Shop drawings must be checked to ensure that the correct panels are being used in the correct location along the wall.
- ▶ It is generally preferable to start a wall at the lowest leveling pad elevation and at the location of any fixed point such as a corner and/or existing structure. (See Image E.)
- ▶ The bottom course is made up of alternating tall panels (A or B3) and half panels (B1 or B2), with the tall A panels above the half panels as shown in Figure 9.
- ▶ The alignment of the first course of panels will determine to a large degree the resulting appearance of the wall. Considerable attention must be paid to the setting and positioning of these panels.
- ▶ Remove the panels from the stack using proper lifting devices. Wood blocking must be placed under the bottom of the panel prior to lifting. (See Figure 7.) This protects the face of the panel being lifted from being scarred by the lower panel.
- ▶ Prior to setting any panel, sweep off the top of the leveling pad or lower panel, and the bottom of the panel being set, to assure that no foreign material will potentially be trapped under the panel, which could affect horizontal level. Bearing pads are not required between the leveling pad and the panels of the bottom course.



IMAGE G: Upper leveling pad offset 9 in.



IMAGE H: Bracing of ARES® panels.



IMAGE I: Establishing batter of ARES® panels.

Below is the suggested sequence for placing panels on the bottom course: It is important to note that the panel should NOT be released prior to the step specifically calling for that action in the following sequence:

- ▶ Lower the panel into position on the pad, using one person on each end of the panel. (See Image H.)
- ▶ Using crowbars, position the base of the panel so that it matches the chalk line.
- ▶ Use a temporary spacer to assure that the $\frac{3}{4}$ in. (19 mm) space across the vertical joint is consistently provided between panels. (See Image J.) Without the correct joint spacing, panel corners may crack and spall.
- ▶ Check the panel for horizontal level; shim if required. (See Figure 11.) If it is not level, shims are placed under the panel in order to make the panel level. Galvanized metal washers or rubber shims are allowed. A maximum $\frac{3}{8}$ in. (9.5 mm) in total shim height at any location is allowed. If more shims are required then the leveling pad is not level.
- ▶ Set the batter on the panel. (See “An Important Note on Batter” on pg. 15.)

NOTE: Shims shall consist of permanent material that will not deteriorate.

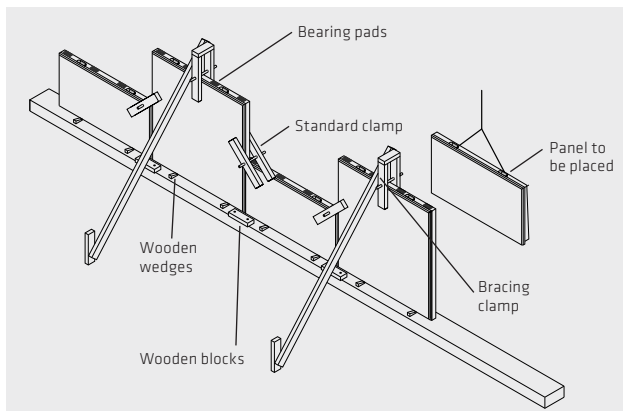

FIGURE 10: Layout of bearing pads, wedges and clamps.

- ▶ Using the 4 ft (1.2 m) level with a predetermined blocking attached to one end, push the top of the panel back until the level reads plumb. (See Image I.)
- ▶ On the taller panels, install a header clamp and brace and tighten the clamp securely. Drive a stake in front of the wall at the midpoint of the panel for adequate bracing. (See Figure 10.) Nail the bottom of the brace into the stake. Check the batter and then nail the brace to the header clamp.
- ▶ On the half-panels, the header clamp and staking are not necessary; the half-panels should be held in place by clamping to the adjacent taller panels. At every vertical joint, position a standard clamp at the top of the half-panel (such that it will result in one clamp on either end of the half-panel) and loosely fasten it. (See Figure 10.)
- ▶ The panel may be released at this point.
- ▶ Tighten the clamps, pulling the half-panel to the same batter as the taller panel, and recheck the panels for alignment, batter and level.
- ▶ Drive wedges at the quarter points of the bottom front of the panel to maintain the batter.
- ▶ Nail 2 x 4 wooden blocks at the joint of the panel to prevent sliding during backfill of the first course. (See Figure 10.)

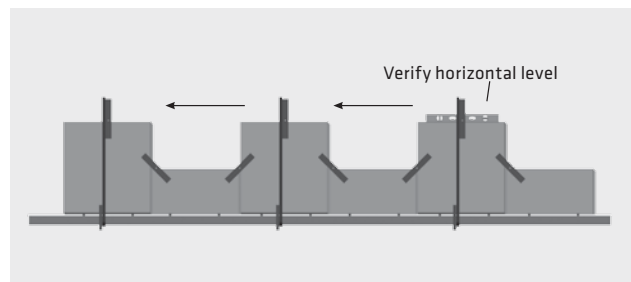

FIGURE 11: Verifying horizontal level.



IMAGE J:
Placement of
5 x 5 panels.

Subsequent Course:
Panels placed,
positioned, aligned,
clamped, battered
and wedged; all but
the top course have
been backfilled.

Below is the suggested sequence for placing panels on all subsequent courses: It is important to note that the panel should NOT be released prior to the step specifically calling for that action in the following sequence:

- ▶ Subsequent panel rows are placed between panels that were previously placed. The ability to properly space and align these rows relies on the proper placement of the lower rows. All of the error produced by the lower rows is propagated upward and is difficult to correct. The same leveling, joint spacing, vertical and horizontal alignment applies to all of these rows as well.
- ▶ Prior to placing a panel on a subsequent course, the panel below should be backfilled to the point that the uppermost layer of geogrid attached to it is covered with at least one lift of compacted fill.
- ▶ Check the batter of the panel below the panel being set. Constant attention to the amount of rotation that is occurring in the adjacent panels and compensating in the following panels will yield the best results.
- ▶ Place bearing pads on lower panel. (See Images J and M.)
- ▶ Lower the panel into position on the bearing pads on the lower panel, using one person on each end of the panel.
- ▶ Using crowbars, position the panel and visually align it with the adjacent panels. (See Figure 12.)
- ▶ Check that the ¾ in. (19 mm) space across the vertical joint is consistently provided between panels. (See Image J.)
- ▶ Check the panel for horizontal level and shim if required. This is particularly important for taller walls to prevent alternate opening and closing of the vertical joints.
- ▶ Wedges may be temporarily placed in the vertical joints to maintain alignment until another panel is placed on top.
- ▶ Position and loosely fasten a standard clamp on each side of the new panel.
- ▶ The panel may be released at this point.
- ▶ Set the batter on the panel. (See “An Important Note on Batter” on pg. 15.)
- ▶ Tighten both side clamps and recheck the panel for alignment, batter and level.
- ▶ Drive the hardwood wedges at the quarter points between the top of the lower panel and the bottom of the new panel to assist in maintaining batter. These wedges should be checked during compaction and re-driven if they become loose.

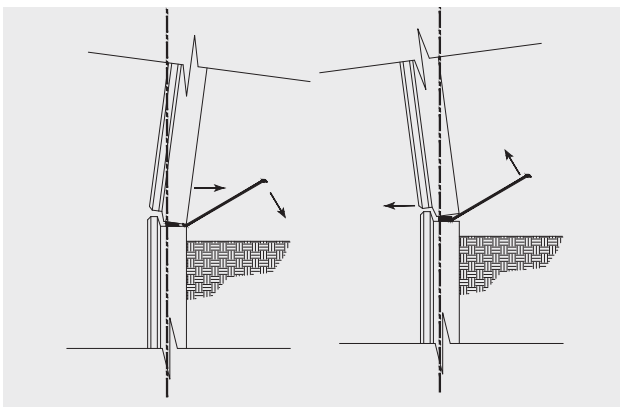

FIGURE 12: Use of crowbars to align ARES® panels.



IMAGE K: Preslit fabric at geogrid elevations.



IMAGE L: Placement of filter fabric at ARES® vertical joint.

Construction Procedures for ARES® Retaining Wall Systems (continued)

AN IMPORTANT NOTE ON BATTER

The amount of batter to which the panel is set is a function of the type, gradation and moisture content of the select fill. It is recommended that the batter in sands be initially set at 1 in. (25 mm) in 4 ft (1.2 m), and for coarser material be set at ¾ in. (19 mm) in 4 ft (1.2 m). The batter on subsequent rows of panels should be adjusted based on the results of the previous courses of panels when they have been backfilled to the top. Note also, particularly in sand backfill, that the required batter tends to be less on panels with more than two layers of geogrid and spaced vertically less than 30 in. (750 mm) apart. Guidance for determining and adjusting the batter is available from the Tensar technical advisor.

NOTE: Failure to properly use wedges and clamps may result in excessive rotation of the panel.

The lowest wedges in the column should be removed from the panels after three levels of wedges are in place above. Failure to remove wedges at this time can make subsequent removal difficult and may cause spalling of the concrete.

The vertical alignment of the overall wall should be checked daily using a plumb bob. These checks should be used to adjust the batter to which the panel is set. For example, if a batter of ¾ in. (19 mm) was used initially and after backfilling the batter measured with a plumb bob is ¼ in. then the next

course should be set with ½ in. (13 mm) batter. If the panel gets a negative batter of ¼ in. (6 mm) after backfill is placed, the next course should be set with an additional ¼ in. batter. If for any reason the backfill source changes this process should be repeated. Monitoring and adjusting the batter of the panels will help maintain the vertical wall tolerances as required by the contract documents.

PLACING THE JOINT MATERIALS

- ▶ The Contractor should place the required bearing pads equally spaced along each horizontal joint between panels.
- ▶ Filter fabric is placed across the joints so that the backfill does not pipe through the joints to the outside of the wall. The minimum lap on each side of the joint is 6 in. and 1 ft along any cut piece of fabric along the joint. These requirements apply to horizontal and vertical joints. (See Image N.)
- ▶ The filter fabric is typically provided in a 12 in. (300 mm) wide strip and should be centered over all panel-to-panel joints and at special locations as shown in the contract documents where the wall abuts to other structures. The fabric should be slit around the embedded geogrid tabs.

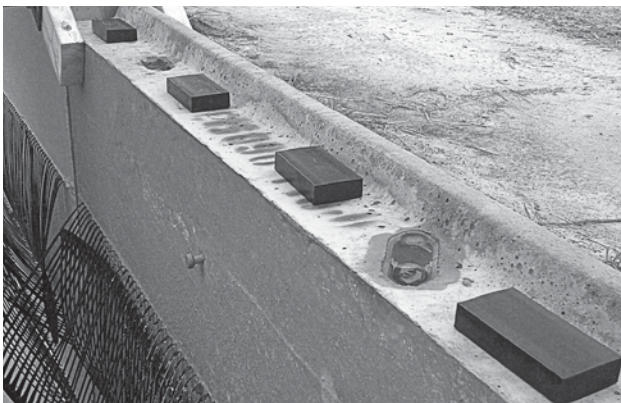

IMAGE M: Common location of bearing pads.



IMAGE N: Filter fabric at vertical joint of ARES panels.



IMAGE O: Uniaxial geogrid shall be tensioned prior to fill placement.



IMAGE P: Placement of fill on tensioned geogrid.

The following procedures are recommended for filter fabric preparation and installation:

- ▶ Once the filter fabric is cut, lay the filter fabric down and mark the location of the geogrid tab on the fabric.
- ▶ Pre-slit the fabric at the marked location to fit around the geogrid tabs. **NOTE:** Use a sharp blade.
- ▶ Use construction adhesive to hold the filter fabric in place prior to select fill placement. Adhesive to be applied surrounding the fabric about 2 in. from the edges including the area where the filter fabric is slit. The filter fabric needs to fully engage the back of the ARES® panels at all locations to ensure that the backfill does not leak through the joints.

GEOGRID IDENTIFICATION

- ▶ The Contractor is recommended to highlight the geogrid types on the construction drawings and spray paint the geogrid tab cast-in the back of the panels before fill placement using colors corresponding to colors of geogrid roll edges. (See pg. 10.)
- ▶ It is also recommended to label the geogrid embedment length for the particular section of the panel on the back of the panel face to ease installation prior to fill placement. (See pg. 10.)

PLACEMENT OF THE GEOGRID

- ▶ Install the UX Geogrid called for on the approved construction drawings, using the type, width and length of geogrid shown for each location within the wall. Installation of the geogrid must be coordinated with the panel and fill placement. The geogrid must be connected to the panels using the Bodkin connection as shown on the approved construction drawings.

- ▶ At the Contractor's discretion, prior to fill placement, the geogrid may be connected to the panels and then the geogrid may be temporarily flipped over the front face of the wall. The select fill shall be brought up to the level of the geogrid connection after compaction and shall be compacted and level for the entire geogrid embedment length prior to placing the geogrid.
- ▶ The Contractor should take care to ensure the level of the compacted fill is flush to the back face of the panel and up to the level of the geogrid connection.
- ▶ The geogrid shall not be placed on the grade until the necessary testing and acceptance of the in-place fill material has been obtained from the Engineer.
- ▶ The geogrid shall be positioned near perpendicular to the face of the panel and such that the tension is relatively uniform across the width of the connection and such that the geogrid lays flat on the grade for the entire embedment length.
- ▶ A tensioning rake is then inserted in front of one of the transverse bars to provide adequate tensioning from the panel and pushed down into the select fill (See Image O). The geogrid is then pulled with sufficient force to remove all slack. Proper technique is important to apply and maintain proper tension.
- ▶ While maintaining tension on the geogrid, select fill should be placed on the geogrid between the rake and the back of the panels (preferably immediately beyond the 3 ft (0.9 m) zone behind the panels). (See Image P.)
- ▶ The rake may be withdrawn immediately after initial placement of about one cubic yard (.76 m³) loose, nominal or more of select fill on the section of geogrid.



IMAGE Q: Geogrid tensioning and fill placement process.



IMAGE R: Use only lightweight equipment to compact fill within 3 ft of ARES® panel.

FOR 5 FT X 9 FT PANELS AND 5 FT X 10 FT PANELS

- ▶ Unless otherwise noted on the approved construction drawings, two full widths of the proper type and length of geogrid shall be attached to each standard-width panel at each elevation requiring geogrid.

REINFORCEMENT FILL PLACEMENT

- ▶ Fill placement shall be performed in a manner that prevents the development of slack in the UX Geogrid. The select fill should be spread in a direction away from or parallel to the face of the wall. In this way, any slack that does develop will tend to be shoved toward the free (back) end of the geogrid. Further care should be taken during fill placement to avoid shoving the geogrid panels and causing them to shift sideways.
- ▶ Place and compact the select fill in accordance with the approved construction drawings and the contract documents. The select fill shall be compacted to a minimum of 95% of the maximum dry density as determined in accordance with AASHTO T-99 or as required by the contract documents, whichever is more stringent. Unless otherwise directed by the Engineer, the select fill lift thickness shall not exceed 10 in. (250 mm)

loose. The lift thickness allowed is at the discretion of the Engineer, provided the Contractor can meet compaction requirements and maintain proper alignment.

- ▶ Static rolling is typically adequate for achieving the required compaction; heavy vibratory equipment may cause movement of wall components and potential misalignment of the wall facing, particularly in sand fill. The actual procedure used should be determined based on field trial results.
- ▶ Only hand-operated lightweight compaction equipment shall be used within 3 ft (0.9 m) of the back face of the panel. (See Image R.) Lightweight vibratory equipment and/or lightweight roller may be used for this purpose. The use of a Jumping Jack is not recommended.
- ▶ Tracked construction equipment shall not be operated directly on the geogrid. A minimum of 6 in. (150 mm) of fill is required between the tracks and the geogrid. Rubber-tired equipment may be operated directly on the geogrid, provided the subgrade is not pumping or rutting. Turning of all equipment shall be minimized to prevent dislocation or damage to the geogrid. The equipment must travel slowly and with sufficient care to avoid dislocating the geogrid.



IMAGE S: Bodkin connection used to connect geogrid panels to geogrid tab.



IMAGE T: Compacted select fill brought up to the level of the geogrid.



- ▶ At the end of each day, the Contractor must ensure that the reinforced fill zone is compacted and graded to drain away from the face of the wall and that berms or ditches are in place and functioning to prevent the entrance of runoff into the wall construction site.
- ▶ **Proper installation and tensioning of the geogrid and select fill is critical to the alignment, appearance and performance of the ARES® Retaining Wall Systems. Care should be taken to ensure that the geogrid is properly tensioned and select fill is properly placed.**

WALL TOLERANCES

Unless otherwise noted on the approved construction drawings or in the contract documents, ensure the following:

- ▶ Deviation in vertical and horizontal alignment does not exceed $\frac{3}{4}$ in. (19 mm) when measured with a 10 ft (3 m) straightedge. Offsets (measured perpendicular to wall face) at the joints between panels do not exceed $\frac{3}{4}$ in. (19 mm).

- ▶ Gaps at horizontal and vertical joints between adjacent panels are not less than $\frac{1}{2}$ in. (12 mm) and not more than $1\frac{1}{4}$ in. (32 mm).
- ▶ Deviation in the final overall verticality of the completed wall (plumbness from top to bottom) does not exceed $\frac{1}{2}$ in. per 10 ft (4 mm per m) of wall height.

THE ARES® SYSTEMS ADVANTAGE

For more than 30 years industry professionals have been using Tensar® Geogrids to build economical, long-lasting structures. With clear advantages in performance, design and installation, ARES® Systems offer a proven technology for addressing the most challenging projects.

For more information on ARES Systems, call **800-TENSAR-1**, visit www.tensarcorp.com or send an e-mail to info@tensarcorp.com. We are happy to supply you with additional information, system specifications, design details, conceptual designs, preliminary cost estimates, and much more.

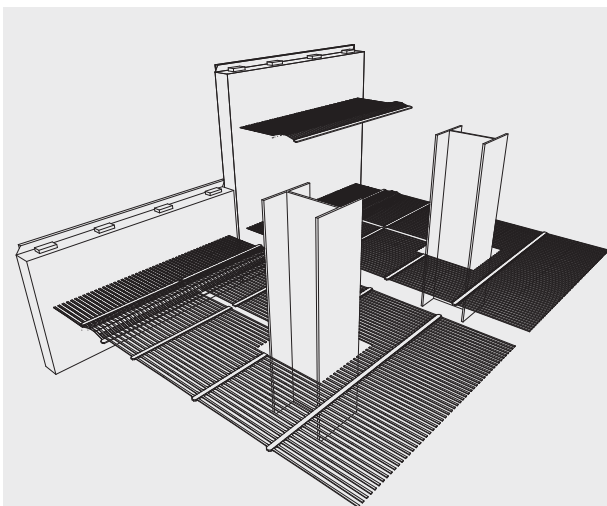
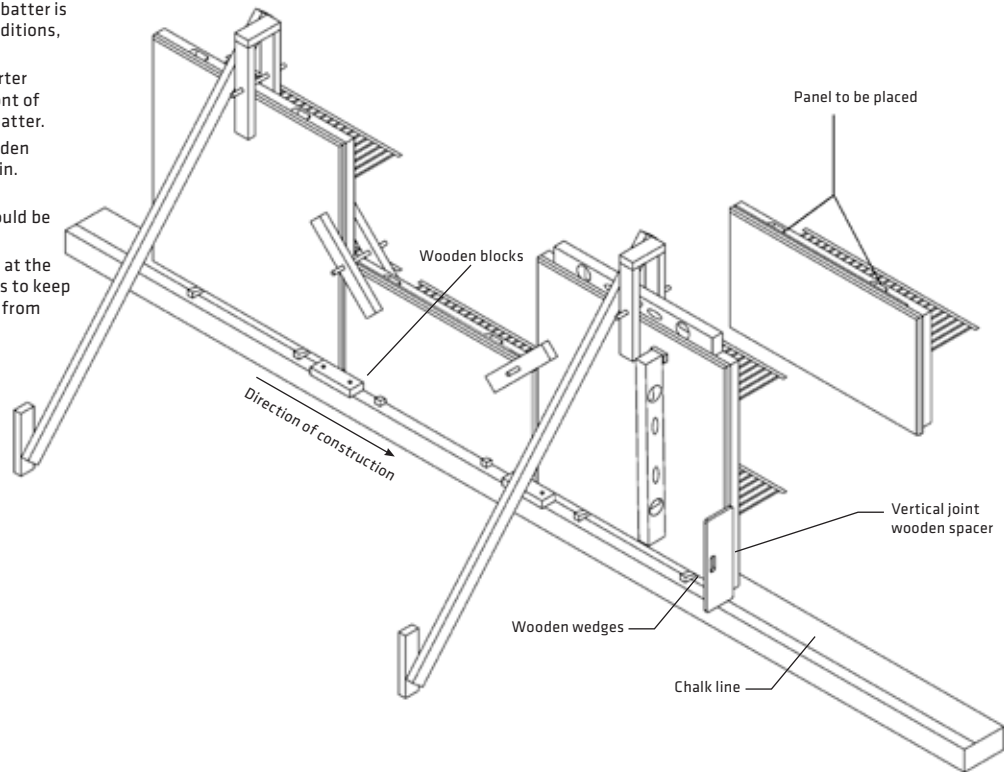

IMAGE U: Placement of geogrid panels around and adjacent to vertical penetrations.

STEP 1:

- ▶ The first row of panels are placed on the leveling pad and braced.
- ▶ The panels should be set with a backward batter according to the panel batter recommendation on page 15. Important: The batter is adjusted for the site conditions, e.g. backfill properties.
- ▶ Drive wedges at the quarter points of the bottom front of the panels to maintain batter.
- ▶ Use a ¾ in. (19 mm) wooden spacer to achieve the ¾ in. (19 mm) vertical joints.
- ▶ Adjacent half panels should be clamped together.
- ▶ Nail 2 x 4 wooden blocks at the joint of the panels; this is to keep the bottom of the panel from "kicking out."



STEP 2:

- ▶ Place the filter fabric over vertical joints.
- ▶ Place and compact initial lifts of selected granular backfill, per project specifications, up to the bottom of the first geogrid tab.
- ▶ Use a hand-operated vibratory compactor in the 3 ft (900 mm) zone behind the panels.

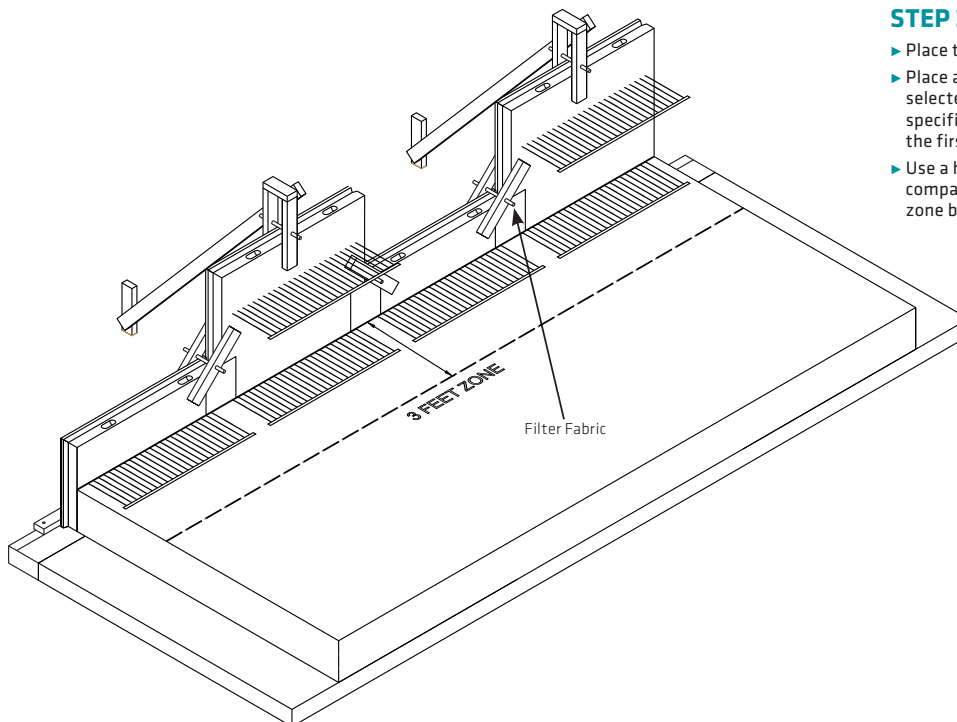

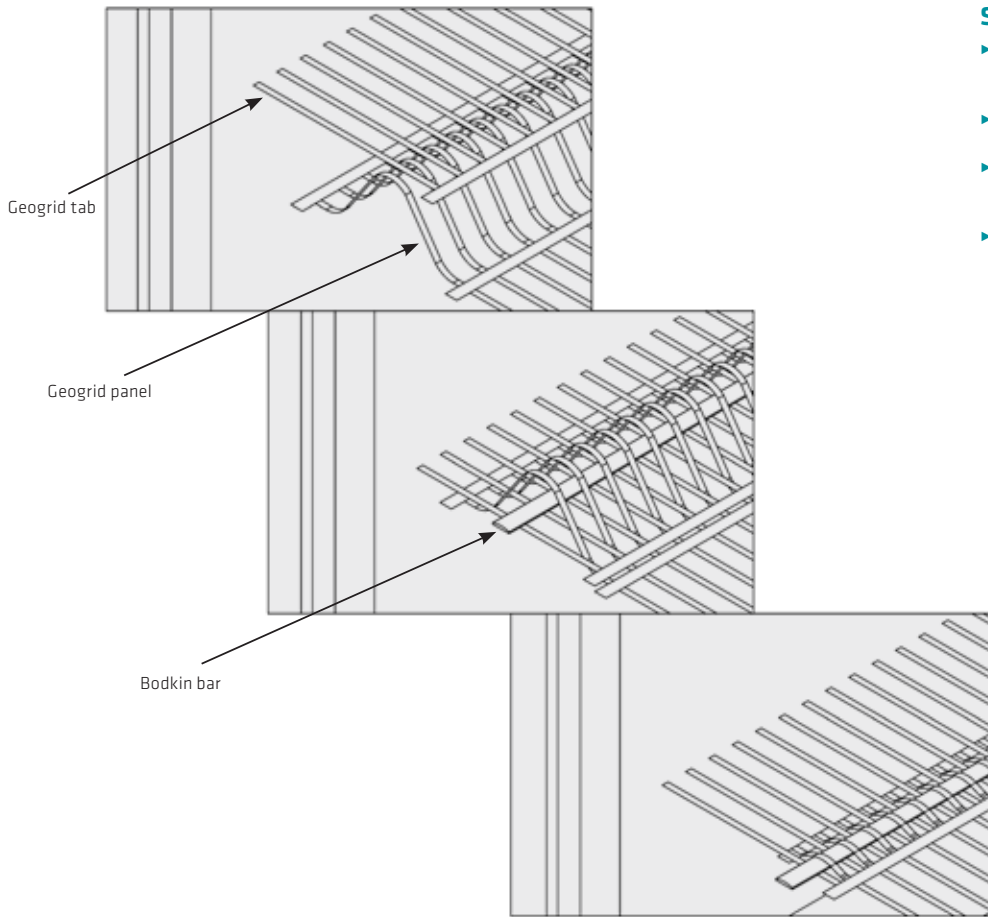

STEP 3:

- ▶ Connect each geogrid panel to the geogrid tab embedded in the panel with the Bodkin bar.
- ▶ Start by bending the geogrid through the tab to create a tunnel.
- ▶ Slide the Bodkin bar through the tunnel that was formed by the geogrid panel and the geogrid tab.
- ▶ Pull the geogrid snug by hand.

STEP 4:

- ▶ When the fill is ready to be placed, tension the geogrid with the tension rake.
- ▶ Start by pushing the rake through the geogrid ribs and press against the transverse bar while driving the rake into the ground.
- ▶ Tension the geogrid using the rake while fill is placed on top of the geogrid panel.
- ▶ Place at least 6 in. (150 mm) of selected granular backfill.
- ▶ The backfill is placed parallel to the wall starting approximately 3 ft (900 mm) from the back of the panels. The fill is then spread toward the geogrid ends.
- ▶ Place the bearing pads equally spaced along each horizontal joint between panels.

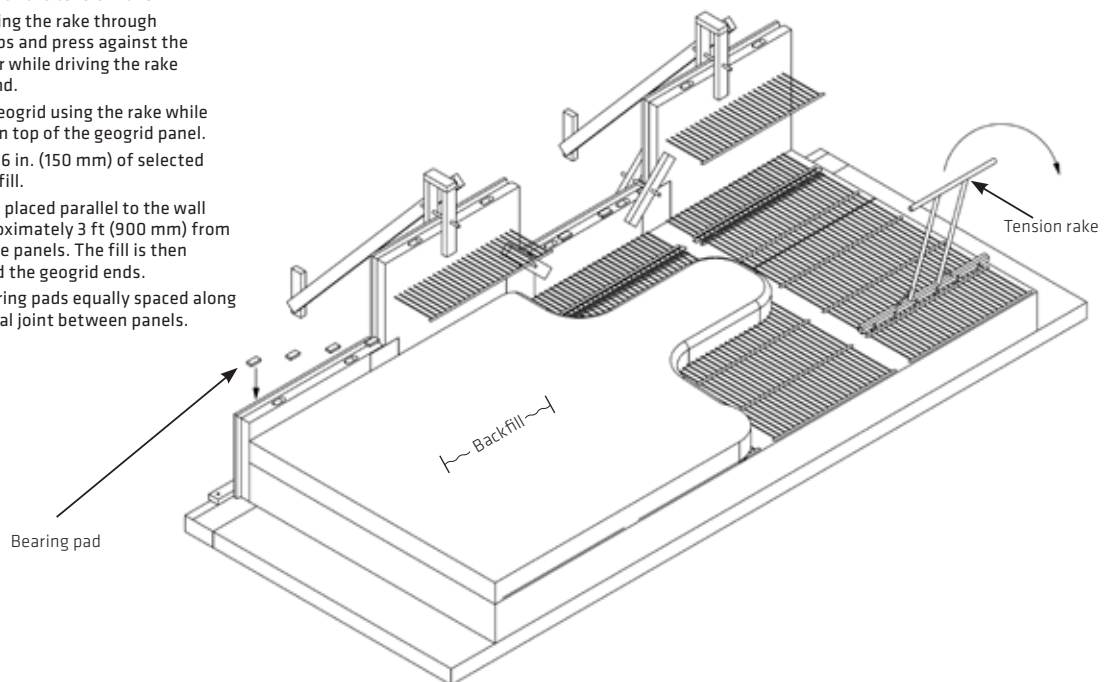

STEP 5:

- ▶ Place the second row of panels only after backfill has reached 6 in. below the half panels.
- ▶ When the next row of panels are ready to be set, remove the clamps.
- ▶ Place the next row of panels in the "window" created by the first course of panels.
- ▶ Check the batter and then install the wedges and clamp to adjacent panels.

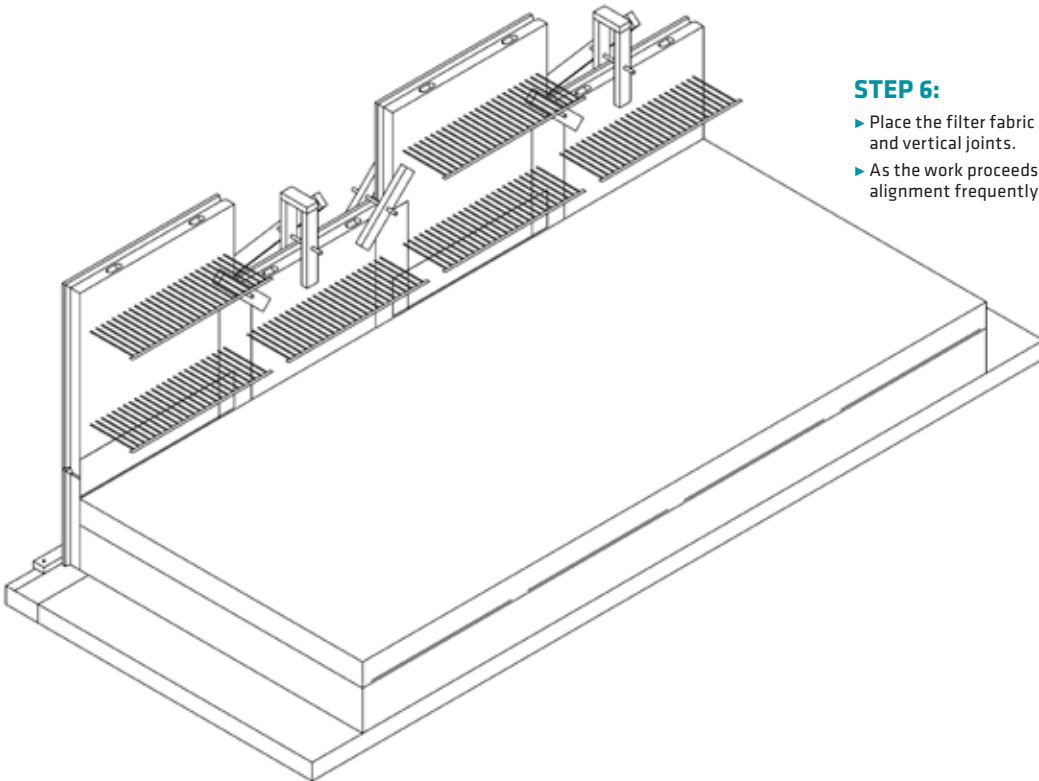
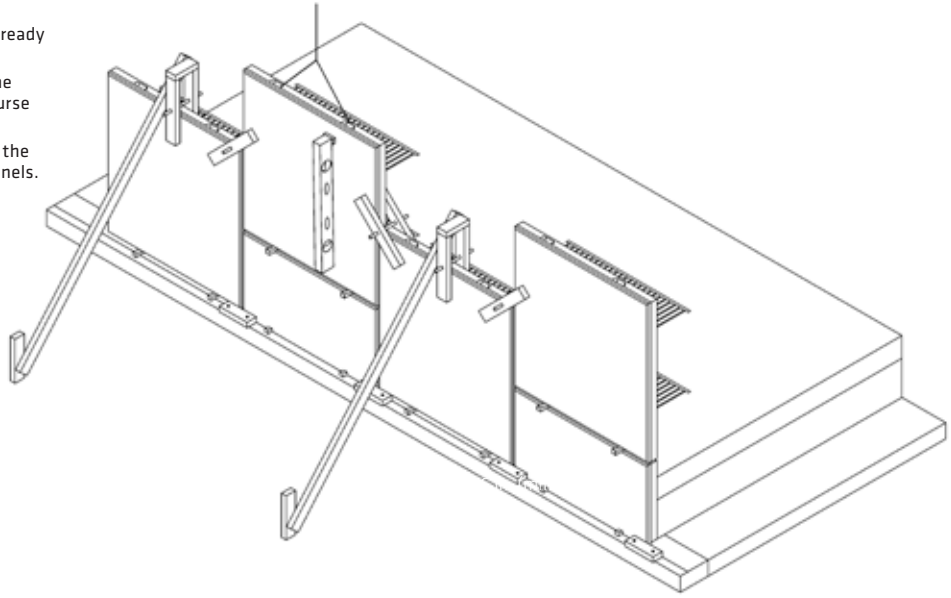

STEP 6:

- ▶ Place the filter fabric over the horizontal and vertical joints.
- ▶ As the work proceeds, check the panel's alignment frequently.

STEP 7:

- ▶ Place selected granular backfill in lifts per project specifications.
- ▶ After backfilling, recheck the batter and alignment of the panels.

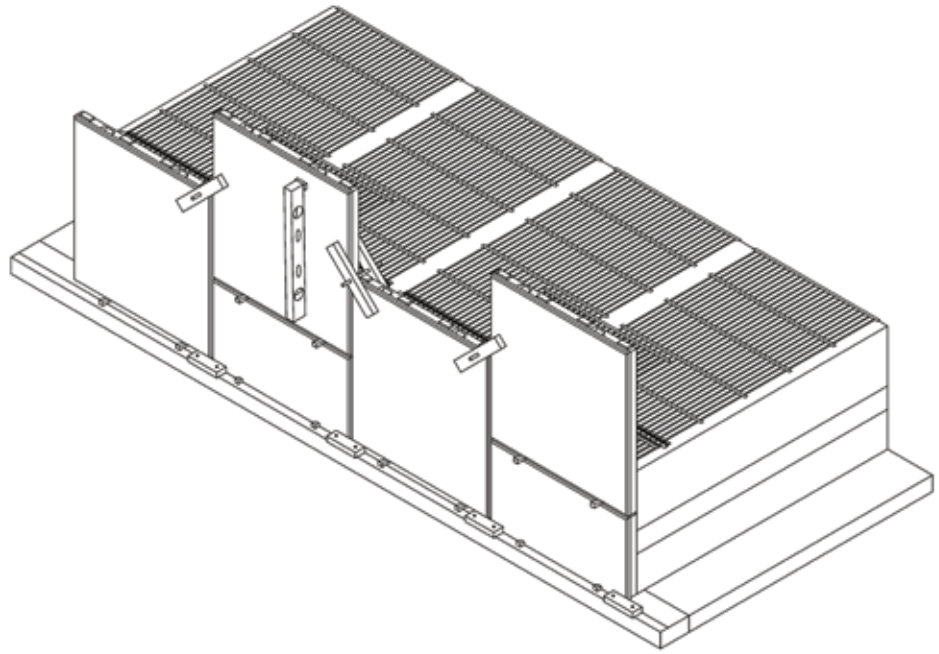

STEP 8:

- ▶ Connect and install geogrid panels as described on step 3.
- ▶ Repeat the process from steps 4 to 7.
- ▶ As soon as practical, the front of the wall should be backfilled.
- ▶ The top wall treatment is then placed per project specifications.

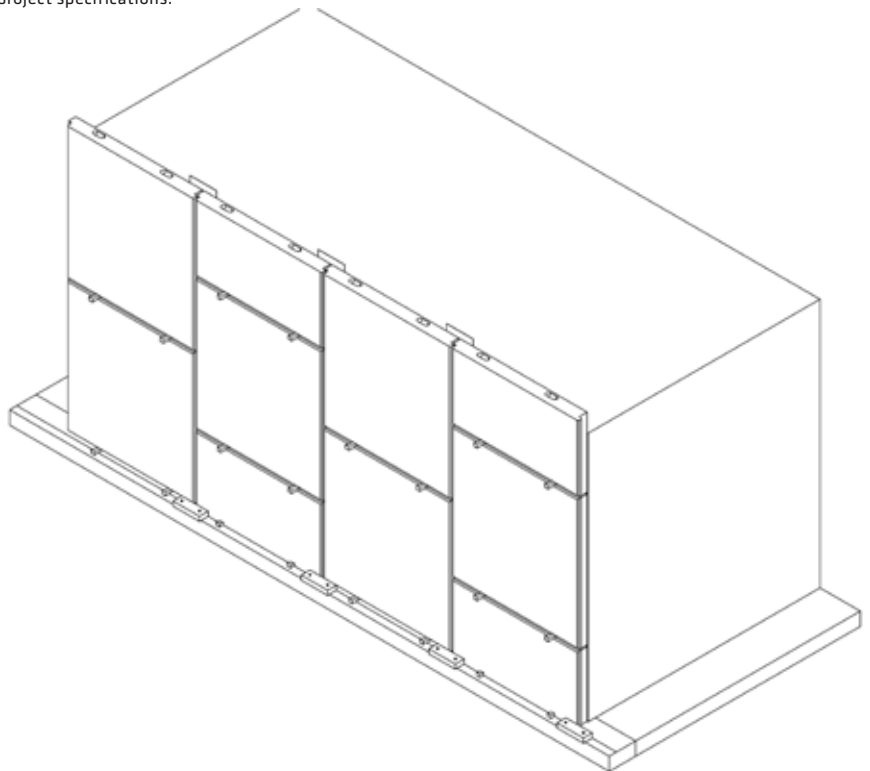



General Terms

Approved Construction Drawings

The final wall drawings provided by Tensar to the Contractor for submittal to the Owner/Owner's Engineer and subsequently approved by the Owner/Owner's Engineer for construction.

Contract Documents

The agreement between the Owner and the Contractor including the plans and specifications, the conditions and provisions of the agreement, including any addenda and other modifications issued prior to or after the bid and the execution of the original contract.

Contractor

The individual, firm or corporation acting directly through its agents or employees to undertake the execution of the work under terms of the contract.

Engineer

The Owner's representative with authoritative charge over the inspection and acceptance of the wall construction in accordance with the contract documents.

Inspector

An authorized representative of the Owner assigned to see that the workmanship and materials are in accordance with the terms of the contract.

Owner

The Owner of the project with whom a contract has been made for payment for the work performed under the terms of the contract.

Plans

The part of the contract documents consisting of the plans, profiles, typical cross-sections, working drawings and supplemental drawings, or exact reproductions thereof, which show the location, character, dimensions and details of the work to be performed.

Precaster

Every precast panel manufacturer under contract with Tensar.

Specifications

The part of the contract documents consisting of a description of the quality and quantity of the materials and workmanship that will be required of the Contractor in the execution of the work under the contract between the Owner and the Contractor.

Tensar Technical Advisor

An authorized representative of Tensar that is available on site at the start of the project to advise the Contractor recommended construction procedures within the scope of this document. This person is not an inspector or member of the quality control staff on the project.

Work

All work items to be performed by the Contractor under the terms and conditions of the contract that are necessary to fulfill the obligations of said contract.

Tensar®

Tensar International Corporation
2500 Northwinds Parkway, Suite 500
Alpharetta, Georgia 30009

800-TENSAR-1
tensarcorp.com

Distributed by: